

# **REDNET<sup>®</sup>**

## **RedNet Installation Guide**

**Focusrite<sup>®</sup>**  
[www.focusrite.com](http://www.focusrite.com)

# TABLE OF CONTENTS

- REDNET 1 ..... 4**
  - Unit Connections and Features ..... 4
    - RedNet 1 - Front Panel ..... 4
    - RedNet 1 - Rear Panel..... 5
  - Physical Characteristics..... 6
  - Power Requirements ..... 6
  - Connectors ..... 7
  - Performance Specifications ..... 9
- REDNET 2 ..... 10**
  - Unit Connections and Features ..... 10
    - RedNet 2 - Front Panel ..... 10
    - RedNet 2 - Rear Panel..... 11
  - Physical Characteristics..... 12
  - Power Requirements ..... 12
  - Connectors ..... 13
  - Performance Specifications ..... 15
- REDNET 3 ..... 16**
  - Unit Connections and Features ..... 16
    - RedNet 3 - Front Panel ..... 16
    - RedNet 3 - Rear Panel..... 17
  - Physical Characteristics..... 19
  - Power Requirements ..... 19
  - Connectors ..... 20
  - Performance Specifications ..... 22
- REDNET 4 ..... 24**
  - Unit Connections and Features ..... 24
    - RedNet 4 - Front Panel ..... 24
    - RedNet 4 - Rear Panel..... 25
  - Physical Characteristics..... 26
  - Power Requirements ..... 26
  - Connectors ..... 27
  - Performance Specifications ..... 29
- REDNET 5 ..... 31**
  - Unit Connections and Features ..... 31
    - RedNet 5 - Front Panel ..... 31
    - RedNet 5 - Rear Panel..... 32
  - Physical Characteristics..... 33
  - Power Requirements ..... 33
  - Interfacing to Pro Tools ..... 34

|   |           |
|---|-----------|
| Pro Tools Setup .....                               | 36        |
| Synchronisation and Clocking .....                  | 37        |
| Connectors .....                                    | 40        |
| Performance Specifications .....                    | 41        |
| <b>REDNET 6 .....</b>                               | <b>42</b> |
| Unit Connections and Features .....                 | 42        |
| RedNet 6 - Front Panel .....                        | 42        |
| RedNet 6 - Rear Panel .....                         | 43        |
| Physical Characteristics .....                      | 44        |
| RedNet 6 Operation .....                            | 45        |
| First Use and Firmware Updates .....                | 45        |
| Digital Clocking .....                              | 45        |
| MADI Modes .....                                    | 46        |
| Pull Up and Pull Down Operations .....              | 46        |
| Sample Rate Converters .....                        | 46        |
| Connector .....                                     | 47        |
| Performance Specifications .....                    | 48        |
| <b>REDNET D16 .....</b>                             | <b>49</b> |
| Unit Connections and Features .....                 | 49        |
| RedNet D16 - Front Panel .....                      | 49        |
| RedNet D16 - Rear Panel .....                       | 50        |
| Power Connection .....                              | 51        |
| Physical Characteristics .....                      | 52        |
| Power Requirements .....                            | 52        |
| RedNet D16 Operation .....                          | 53        |
| Connectors .....                                    | 54        |
| Performance Specifications .....                    | 55        |
| <b>REDNET PCIe .....</b>                            | <b>57</b> |
| Unit Connections and Features .....                 | 57        |
| Installing RedNet PCIe .....                        | 58        |
| <b>INSTALLING REDNET CONTROL .....</b>              | <b>59</b> |
| <b>AUDINATE DANTE CONTROLLER .....</b>              | <b>59</b> |
| <b>CONNECTING YOUR REDNET AUDIO NETWORK .....</b>   | <b>59</b> |
| <b>NETWORK REQUIREMENTS .....</b>                   | <b>60</b> |
| Ethernet Cabling .....                              | 60        |
| Network Switches .....                              | 60        |
| Fibre Optic Networks .....                          | 60        |
| <b>CONNECTION DIAGRAMS AND EXAMPLE SETUPS .....</b> | <b>54</b> |
| <b>WARRANTY AND SERVICE INFORMATION .....</b>       | <b>56</b> |
| <b>SAFETY AND ENVIRONMENTAL DECLARATIONS .....</b>  | <b>57</b> |

# REDNET 1

## UNIT CONNECTIONS AND FEATURES

### RedNet 1 - Front Panel

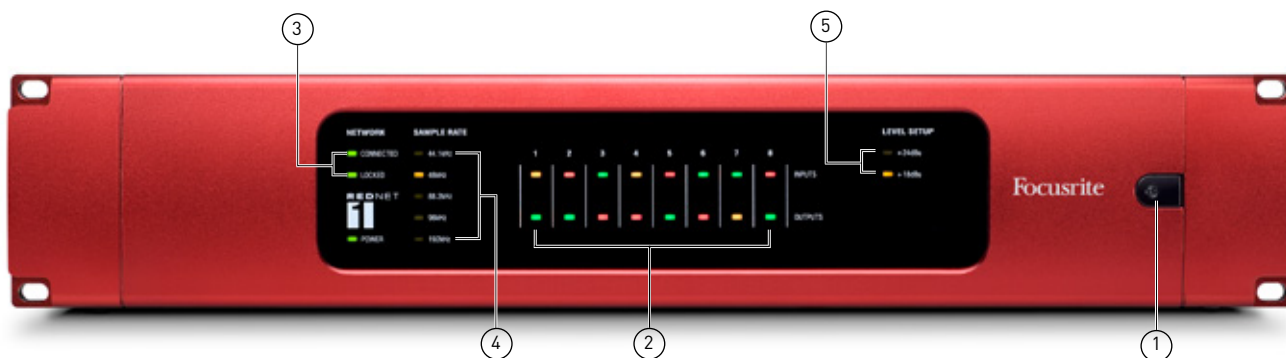

1. AC Power switch
2. Tricolour LEDs indicating signal level at each A-D and D-A converter:
  - Green – signal level above -42 dBFS
  - Yellow – signal level above -6 dBFS
  - Red – signal level is 0 dBFS (digital clipping)
3. **NETWORK** status flags – two green LEDs confirming network status:
  - **CONNECTED** – illuminates when the unit is connected to an active Ethernet network
  - **LOCKED** – illuminates when a valid sync is received via the network
4. **SAMPLE RATE** indication – five yellow LEDs; only one of these (**44.1 kHz, 48 kHz, 88.2 kHz, 96 kHz, 192 kHz**) will be lit at a time, to confirm the sample rate that the system is running at.
5. **LEVEL SETUP** indication – two yellow LEDs; one of these will be illuminated to confirm the analogue reference level set for the unit, **+24 dBu** or **+18 dBu**. This is the analogue level which equates to the internal maximum digital clip level of 0 dBFS.

## RedNet 1 - Rear Panel



6. **ANALOGUE INPUTS 1-8** – 25-pin female Dsub connector for connecting up to 8 analogue sources to the RedNet system. All inputs are electronically balanced. See page 7 for connector details.
7. **ANALOGUE OUTPUTS 1-8** – 25-pin female Dsub connector with 8 analogue outputs from the RedNet system. All outputs are electronically balanced. See page 7 for connector details.
8. **ETHERNET** – RJ45 network socket. Use a standard CAT 6 cable to connect this socket to a local Ethernet switch to connect the RedNet 1 to the RedNet network. The socket has integral LEDs which illuminate to indicate connection to an active network port, and network activity. See page 8 for connector details.
9. **AC mains** – standard IEC receptacle for connection of AC mains. RedNet 1 has a 'Universal' PSU, enabling it to operate from any supply voltages between 100 V and 240 V.

## PHYSICAL CHARACTERISTICS

RedNet 1's dimensions are shown in the diagram below:

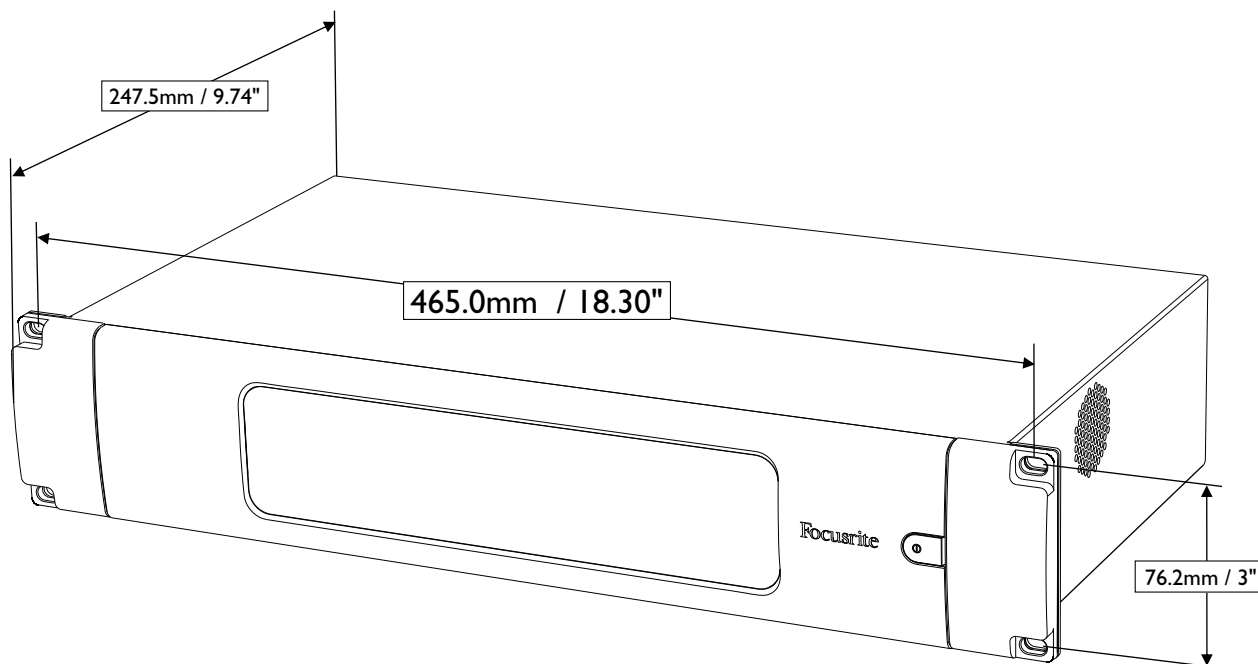

RedNet 1 requires 2U of vertical rackspace and at least 350 mm of rack depth, to allow for cables. RedNet 1 weighs 4.12 kg and for installations in a fixed environment (e.g., a studio), the front panel mounting screws will provide adequate support. If the units are to be used in a mobile situation (e.g., flight-cased for touring, etc.), consideration should be given to using side support rails within the rack.

RedNet 1 generates no significant heat, and is normally cooled by natural convection, though an internal cooling fan is fitted. We recommend that the unit should not be used in locations where the ambient temperature is greater than 30°C(85°F). However, if this is unavoidable, the fan can be turned on and off from RedNet Control.

Ventilation is via slots in the enclosure at both sides. Do not mount RedNet 1 immediately above any other equipment which generates significant heat, for example, a power amplifier. Also, ensure that when mounted in a rack, the side vents are not obstructed.

## POWER REQUIREMENTS

RedNet 1 is mains-powered. It incorporates a 'Universal' power supply, which can operate on any AC mains voltage from 100 V to 240 V. The AC connection is made via a standard 3-pin IEC connector on the rear panel. A mating IEC cable is supplied with the unit, which should be terminated with a mains plug of the correct type for your country.

The AC power consumption of the RedNet 1 is 45 VA.



Please note that there are no fuses in RedNet 1, or other user-replaceable components of any type. Please refer all servicing issues to the Customer Support Team (see "Customer Support and Unit Servicing" on page 55).

## First Use and Firmware Updates

Your RedNet 1 will require a firmware update when it is first installed and switched on. Firmware updates are initiated and handled automatically by the RedNet Control application. It is important that the firmware update procedure is not interrupted, either by switching off the RedNet 6 or the computer on which RedNet Control is running or disconnecting either from the network.

From time to time Focusrite will release RedNet firmware updates with new versions of RedNet Control. We recommend keeping all RedNet units up to date with the latest firmware version supplied with each new version of RedNet Control.

## CONNECTORS

### 8-channel analogue input and output connectors

Connector type: 25-pin female Dsub  
 Applies to: ANALOGUE INPUTS 1-8  
 ANALOGUE OUTPUTS 1-8  
 Standard: AES 59 (AKA Tascam wiring)

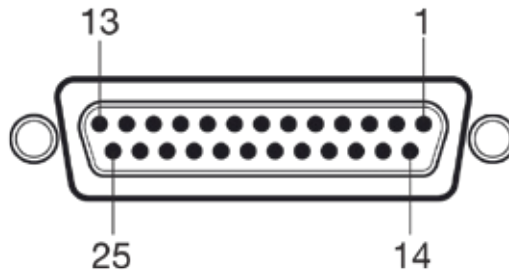

| Pin | Signal         |  | Pin | Signal          |
|-----|----------------|--|-----|-----------------|
| 1   | Ch 8 'hot' (+) |  | 14  | Ch 8 'cold' (-) |
| 2   | Ch 8 screen    |  | 15  | Ch 7 'hot' (+)  |
| 3   | Ch 7 cold (-)  |  | 16  | Ch 7 screen     |
| 4   | Ch 6 'hot' (+) |  | 17  | Ch 6 'cold' (-) |
| 5   | Ch 6 screen    |  | 18  | Ch 5 'hot' (+)  |
| 6   | Ch 5 cold (-)  |  | 19  | Ch 5 screen     |
| 7   | Ch 4 'hot' (+) |  | 20  | Ch 4 'cold' (-) |
| 8   | Ch 4 screen    |  | 21  | Ch 3 'hot' (+)  |
| 9   | Ch 3 cold (-)  |  | 22  | Ch 3 screen     |
| 10  | Ch 2 'hot' (+) |  | 23  | Ch 2 'cold' (-) |
| 11  | Ch 2 screen    |  | 24  | Ch 1 'hot' (+)  |
| 12  | Ch 1 cold (-)  |  | 25  | Ch 1 screen     |
| 13  | n/c            |  |     |                 |

Ethernet connector

Connector type: RJ-45 receptacle  
 Applies to: ETHERNET  
 Cable type: CAT 5e or CAT 6

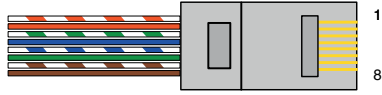

| Pin | Cat 6 Core     |
|-----|----------------|
| 1   | White + Orange |
| 2   | Orange         |
| 3   | White + Green  |
| 4   | Blue           |
| 5   | White + Blue   |
| 6   | Green          |
| 7   | White + Brown  |
| 8   | Brown          |



## PERFORMANCE SPECIFICATIONS

| <b>Inputs</b>                 |   |
|-------------------------------|---|
| Analogue line inputs          | 8   |
| Connector                     | 25-way female Dsub, wired to AES 59                                 |
| 0 dBFS reference levels       | +18 or +24 dBu (switchable)   |
| Frequency response            | 20 Hz – 20 kHz $\pm$ 0.05 dB  |
| THD+N                         | < 0.001% unweighted; -1 dBFS input, 20 Hz – 22 kHz                  |
| Dynamic range                 | 119 dB 'A'-weighted (-60 dBFS method)                               |
| Converter dynamic range       | 120 dB  |
| Signal-to-noise ratio         | 119 dB 'A'-weighted; 20 Hz – 20 kHz                                 |
| <b>Outputs</b>                |   |
| Analogue line outputs         | 8   |
| Connector                     | 25-way female Dsub, wired to AES 59                                 |
| 0 dBFS reference levels       | +18 or +24 dBu (switchable)   |
| Frequency response            | 20 Hz – 20 kHz $\pm$ 0.15 dB  |
| THD+N                         | < 0.001% unweighted; -1 dBFS input, 20 Hz – 22 kHz                  |
| Dynamic Range                 | 119 dB 'A'-weighted (-60 dBFS method)                               |
| Converter dynamic range       | 120 dB  |
| Signal-to-noise ratio         | 119 dB 'A'-weighted; 20 Hz – 20 kHz                                 |
| <b>Crosstalk</b>              |   |
| Input or Output to Input      | <-90 dB (all other channels at 0 dBFS)                              |
| Input or Output to Output     | <-100 dB (all other channels at 0 dBFS)                             |
| <b>Digital Performance</b>    |   |
| Supported sample rates        | 44.1 / 48 / 88.2 / 96 / 192 kHz                                     |
| Clock sources                 | Internal or from network master device                              |
| <b>Power</b>                  |   |
| PSU                           | Internal, Universal type, consumption 45 VA                         |
| <b>Front Panel Indicators</b> |   |
| Power                         | Green   |
| Network connected             | Green   |
| Sync lock                     | Green   |
| Sample rate                   | Yellow x 5  |
| Input/Output range            | Yellow x 2  |
| Input/Output signal level     | Bi-colour x 16 (Green = -42 dBFS; Orange = -6 dBFS; Red = overload) |

# REDNET 2

## UNIT CONNECTIONS AND FEATURES

### RedNet 2 - Front Panel

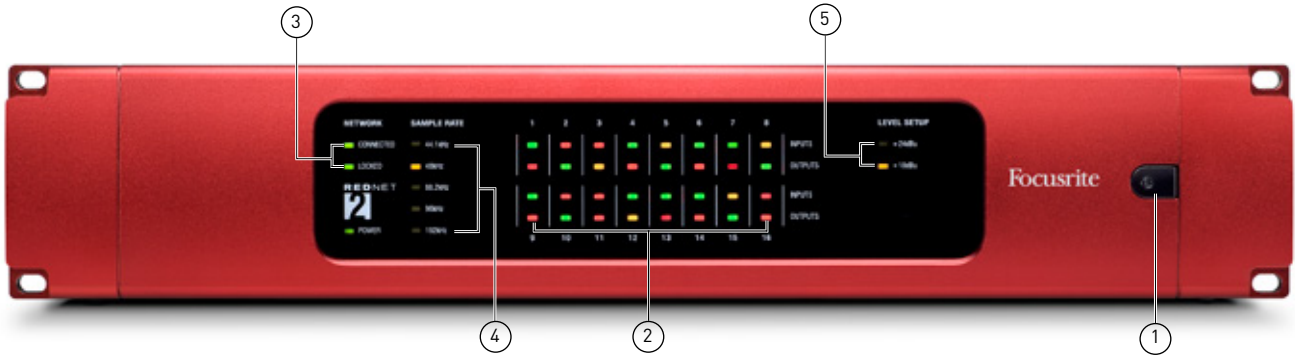

1. AC Power switch
2. Tricolour LEDs indicating signal level at each analogue input and output:
  - Green – signal level above -42 dBFS
  - Yellow – signal level above -6 dBFS
  - Red – signal level is 0 dBFS (digital clipping)
3. **NETWORK** status flags – two green LEDs confirming network status:
  - **CONNECTED** – illuminates when the unit is connected to an active Ethernet network
  - **LOCKED** – illuminates when a valid sync is received via the network
4. **SAMPLE RATE** indication – five yellow LEDs; only one of these (**44.1 kHz, 48 kHz, 88.2 kHz, 96 kHz, 192 kHz**) will be lit at a time, to confirm the sample rate that the system is running at.
5. **LEVEL SETUP** indication – two yellow LEDs; one of these will be illuminated to confirm the analogue reference level set for the unit, **+24 dBu** or **+18 dBu**. This is the analogue level which equates to the internal maximum digital clip level of 0 dBFS.

## RedNet 2 - Rear Panel

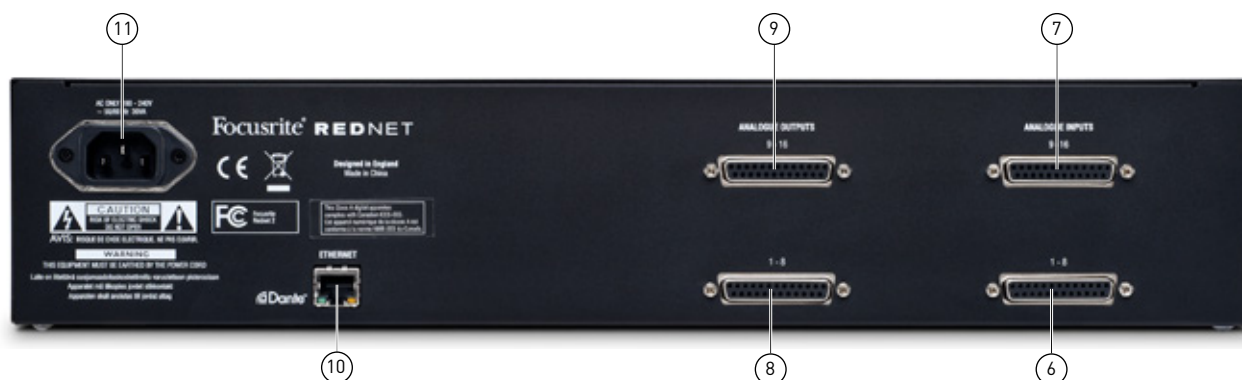

6. **ANALOGUE INPUTS 1-8** – 25-pin female Dsub connector for connecting up to 8 analogue sources to the RedNet system. All inputs are electronically balanced. See page 13 for connector details.
7. **ANALOGUE INPUTS 9-16** – as [6], for channels 9 to 16.
8. **ANALOGUE OUTPUTS 1-8** – 25-pin female Dsub connector with 8 analogue outputs from the RedNet system. All outputs are electronically balanced. See page 13 for connector details.
9. **ANALOGUE OUTPUTS 9-16** – as [8], for channels 9 to 16.
10. **ETHERNET** – RJ45 network socket. Use a standard computer network cable to connect this socket to a local Ethernet switch to connect the RedNet 2 to the RedNet network. The socket has integral LEDs which illuminate to indicate connection to an active network port, and network activity. See page 14 for connector details.
11. **AC mains** – standard IEC receptacle for connection of AC mains. RedNet 2 has a 'Universal' PSU, enabling it to operate from any supply voltages between 100 V and 240 V.

## PHYSICAL CHARACTERISTICS

RedNet 2's dimensions are shown in the diagram below:

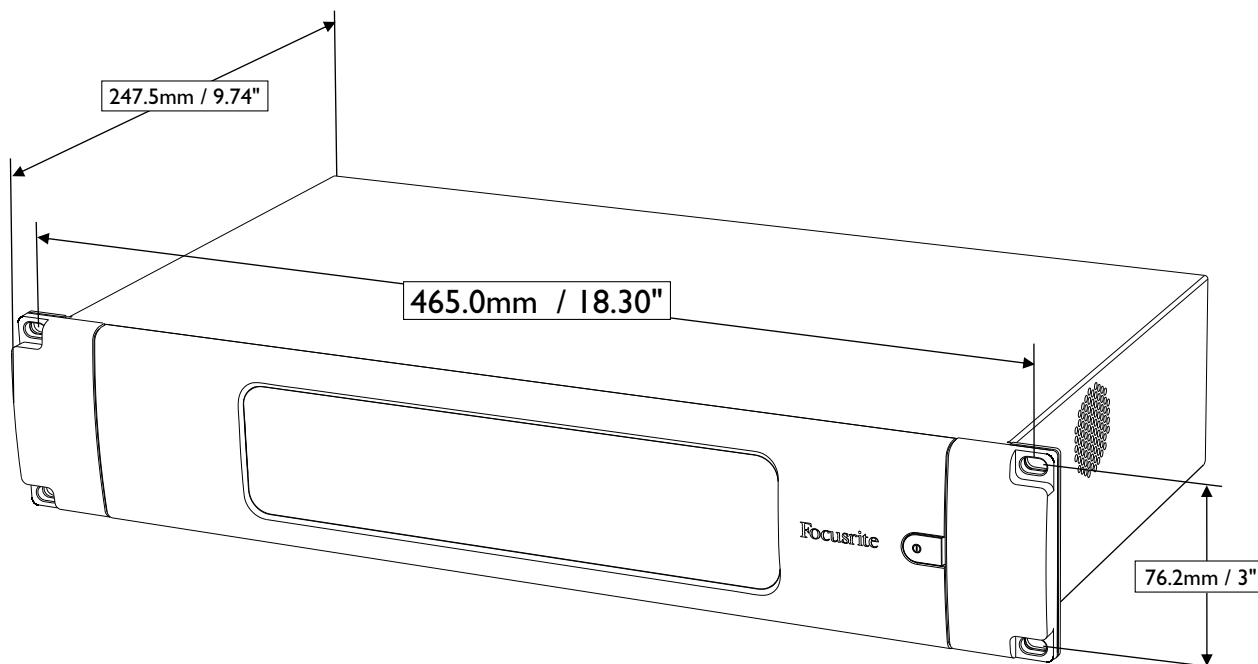

RedNet 2 requires 2U of vertical rackspace and at least 350 mm of rack depth, to allow for cables. RedNet 2 weighs 4.76 kg and for installations in a fixed environment (e.g., a studio), the front panel mounting screws will provide adequate support. If the units are to be used in a mobile situation (e.g., flight-cased for touring, etc.), consideration should be given to using side support rails within the rack.

RedNet 2 generates no significant heat, and is normally cooled by natural convection, though an internal cooling fan is fitted. We recommend that the unit should not be used in locations where the ambient temperature is greater than 30°C. However, if this is unavoidable, the fan can be turned on and off from RedNet Control.

Ventilation is via slots in the enclosure at both sides. Do not mount RedNet 2 immediately above any other equipment which generates significant heat, for example, a power amplifier. Also, ensure that when mounted in a rack, the side vents are not obstructed.

## POWER REQUIREMENTS

RedNet 2 is mains-powered. It incorporates a 'Universal' power supply, which can operate on any AC mains voltage from 100 V to 240 V. The AC connection is made via a standard 3-pin IEC connector on the rear panel. A mating IEC cable is supplied with the unit, which should be terminated with a mains plug of the correct type for your country.

The AC power consumption of the RedNet 2 is 68 VA.



Please note that there are no fuses in RedNet 2, or other user-replaceable components of any type. Please refer all servicing issues to the Customer Support Team (see "Customer Support and Unit Servicing" on page 55).

## First Use and Firmware Updates

Your RedNet 2 will require a firmware update when it is first installed and switched on. Firmware updates are initiated and handled automatically by the RedNet Control application. It is important that the firmware update procedure is not interrupted, either by switching off the RedNet 6 or the computer on which RedNet Control is running or disconnecting either from the network.

From time to time Focusrite will release RedNet firmware updates with new versions of RedNet Control. We recommend keeping all RedNet units up to date with the latest firmware version supplied with each new version of RedNet Control.

## CONNECTORS

### 8-channel analogue input and output connectors

Connector type: 25-pin female Dsub  
 Applies to: ANALOGUE INPUTS 1-8, ANALOGUE INPUTS 9-16  
 ANALOGUE OUTPUTS 1-8, ANALOGUE OUTPUTS 9-16  
 Standard: AES 59 (AKA Tascam wiring)

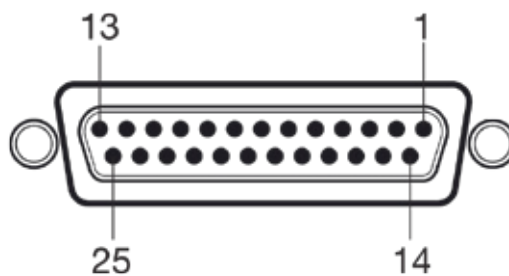

| Pin | Input/Output 1-8 | Input/Output 9-16 |  | Pin | Input/Output 1-8 | Input/Output 9-16 |
|-----|------------------|-------------------|--|-----|------------------|-------------------|
| 1   | Ch 8 'hot' (+)   | Ch 16 'hot' (+)   |  | 14  | Ch 8 'cold' (-)  | Ch 16 'cold' (-)  |
| 2   | Ch 8 screen      | Ch 16 screen      |  | 15  | Ch 7 'hot' (+)   | Ch 15 'hot' (+)   |
| 3   | Ch 7 cold (-)    | Ch 15 cold (-)    |  | 16  | Ch 7 screen      | Ch 15 screen      |
| 4   | Ch 6 'hot' (+)   | Ch 14 'hot' (+)   |  | 17  | Ch 6 'cold' (-)  | Ch 14 'cold' (-)  |
| 5   | Ch 6 screen      | Ch 14 screen      |  | 18  | Ch 5 'hot' (+)   | Ch 13 'hot' (+)   |
| 6   | Ch 5 cold (-)    | Ch 13 cold (-)    |  | 19  | Ch 5 screen      | Ch 13 screen      |
| 7   | Ch 4 'hot' (+)   | Ch 12 'hot' (+)   |  | 20  | Ch 4 'cold' (-)  | Ch 12 'cold' (-)  |
| 8   | Ch 4 screen      | Ch 12 screen      |  | 21  | Ch 3 'hot' (+)   | Ch 11 'hot' (+)   |
| 9   | Ch 3 cold (-)    | Ch 11 cold (-)    |  | 22  | Ch 3 screen      | Ch 11 screen      |
| 10  | Ch 2 'hot' (+)   | Ch 10 'hot' (+)   |  | 23  | Ch 2 'cold' (-)  | Ch 10 'cold' (-)  |
| 11  | Ch 2 screen      | Ch 10 screen      |  | 24  | Ch 1 'hot' (+)   | Ch 9 'hot' (+)    |
| 12  | Ch 1 cold (-)    | Ch 9 cold (-)     |  | 25  | Ch 1 screen      | Ch 9 screen       |
| 13  | n/c              | n/c               |  |     |                  |                   |

## Ethernet connector

Connector type: RJ-45 receptacle  
Applies to: ETHERNET  
Cable type: CAT 5e or CAT 6

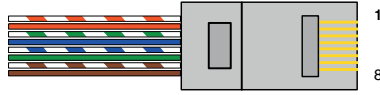

| Pin | Cat 6 Core     |
|-----|----------------|
| 1   | White + Orange |
| 2   | Orange         |
| 3   | White + Green  |
| 4   | Blue           |
| 5   | White + Blue   |
| 6   | Green          |
| 7   | White + Brown  |
| 8   | Brown          |

## PERFORMANCE SPECIFICATIONS

| <b>Inputs</b>                 |   |
|-------------------------------|---|
| Analogue line inputs          | 16  |
| Connector                     | 25-way female Dsub x 2, wired to AES 59                             |
| 0 dBFS reference levels       | +18 or +24 dBu (switchable)   |
| Frequency response            | 20 Hz – 20 kHz $\pm$ 0.05 dB  |
| THD+N                         | < 0.001% unweighted; -1 dBFS input, 20 Hz – 22 kHz                  |
| Dynamic range                 | 119 dB 'A'-weighted (-60 dBFS method)                               |
| Converter dynamic range       | 120 dB  |
| Signal-to-noise ratio         | 119 dB 'A'-weighted; 20 Hz – 20 kHz                                 |
| <b>Outputs</b>                |   |
| Analogue line outputs         | 16  |
| Connector                     | 25-way female Dsub x 2, wired to AES 59                             |
| 0 dBFS reference levels       | +18 or +24 dBu (switchable)   |
| Frequency response            | 20 Hz – 20 kHz $\pm$ 0.15 dB  |
| THD+N                         | < 0.001% unweighted; -1 dBFS input, 20 Hz – 22 kHz                  |
| Dynamic Range                 | 119 dB 'A'-weighted (-60 dBFS method)                               |
| Converter dynamic range       | 120 dB  |
| Signal-to-noise ratio         | 119 dB 'A'-weighted; 20 Hz – 20 kHz                                 |
| <b>Crosstalk</b>              |   |
| Input or Output to Input      | < -90 dB (all other channels at 0 dBFS)                             |
| Input or Output to Output     | < -100 dB (all other channels at 0 dBFS)                            |
| <b>Digital Performance</b>    |   |
| Supported sample rates        | 44.1 / 48 / 88.2 / 96 / 192 kHz                                     |
| Clock sources                 | Internal or from network master device                              |
| <b>Power</b>                  |   |
| PSU                           | Internal, Universal type, consumption 68 VA                         |
| <b>Front Panel Indicators</b> |   |
| Power                         | Green   |
| Network connected             | Green   |
| Sync lock                     | Green   |
| Sample rate                   | Yellow x 5  |
| Input/Output range            | Yellow x 2  |
| Input/Output signal level     | Bi-colour x 32 (Green = -42 dBFS; Orange = -6 dBFS; Red = overload) |

# REDNET 3

## UNIT CONNECTIONS AND FEATURES

### RedNet 3 - Front Panel

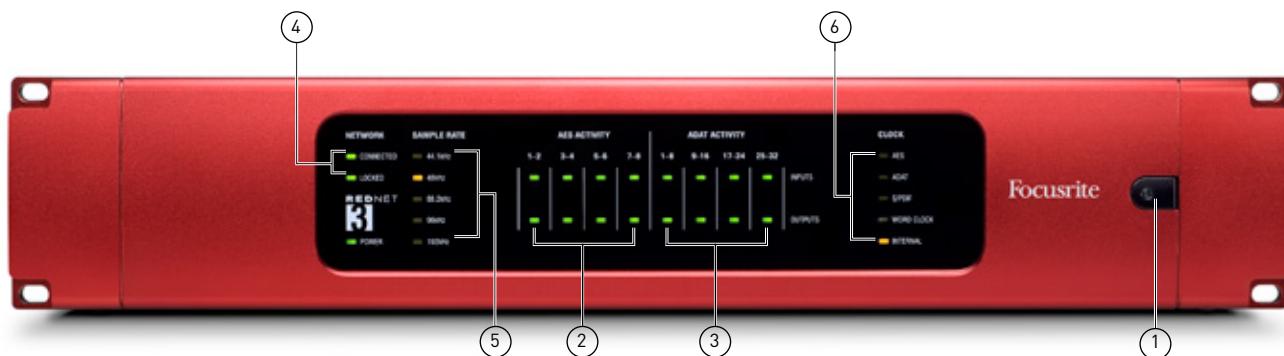

1. AC Power switch
2. **AES ACTIVITY** – four green LEDs which illuminate when a valid AES/EBU digital audio signal is present at the corresponding AES/EBU input. A further set of four indicates the presence of a signal at each of the AES/EBU outputs. Note that the numbering is in pairs, as one AES/EBU signal (input or output) corresponds to two audio channels.
3. **ADAT ACTIVITY** – two sets of four green LEDs which illuminate when a valid digital audio signal in ADAT format is present at the corresponding input or output TOSLINK port. Note that as one port (input or output) can carry 8 channels of audio at a sample rate of 44.1 or 48 kHz, but correspondingly less at higher sample rates, the number of LEDs which will be active is dependent both on the number of ports in use and the sample rate. For channel counts of each port at various sample rates, please refer to the specification table later in the guide
4. **NETWORK** status flags – two green LEDs confirming network status:
  - **CONNECTED** – illuminates when the unit is connected to an active Ethernet network
  - **LOCKED** – illuminates when a valid clock sync is received via the network or an external source
5. **SAMPLE RATE** indication – five yellow LEDs; only one of these (**44.1 kHz, 48 kHz, 88.2 kHz, 96 kHz, 192 kHz**) will be lit at a time, to confirm the sample rate that the system is running at.



6. **CLOCK** – One of five yellow LEDs will be illuminated to confirm the currently selected source of clock for the RedNet 3 unit if it is currently selected as Preferred Master in RedNet Control. The clock source is selected in software from RedNet Control, and the options are:
- **AES** – sync is derived from Channel 1 of the AES/EBU digital audio input.
  - **ADAT** – sync is derived from ADAT input 1.
  - **S/PDIF** – an S/PDIF digital audio signal connected at the rear panel may be used as the sync source.
  - **WORD CLOCK** – a dedicated word clock input is provided on the rear panel to permit RedNet 3 – and the entire RedNet network – to be locked to a studio master word clock source.
  - **INTERNAL** – synchronisation is derived from the RedNet 3's internal clock. If any of the external sync sources are selected, but no valid signal is available, the unit's clock source will switch automatically to internal sync. The network clock (whether derived from an external clock, RedNet 3's internal clock or another Dante device on the network) is available at the Word Clock Output connector for connection to other digital audio devices outside the network.

## RedNet 3 - Rear Panel

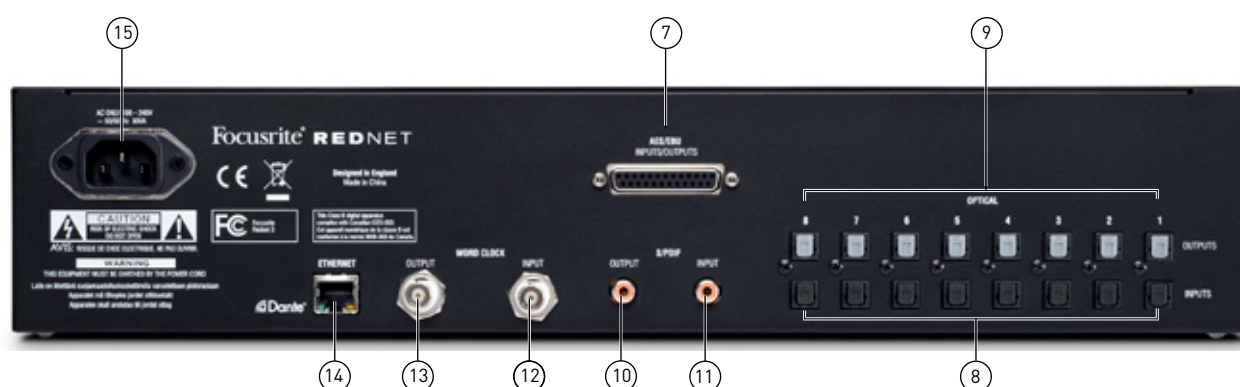

7. **AES/EBU INPUTS/OUTPUTS** – 25-pin female Dsub connector, conforming to AES 59, for connecting up to 8 digital audio sources (4 AES/EBU pairs) to the RedNet system, and also for outputting up to 8 digital audio channels (4 AES/EBU pairs). See page 20 for connector details.
8. **OPTICAL INPUTS 1-8** – these are for connection to a multichannel audio source with ADAT-format optical outputs. The connectors are TOSLINK type. Note that each connector carries eight separate audio channels at 44.1/48 kHz sample rate, four at 88.2/96 kHz, or two at 192 kHz.
9. **OPTICAL OUTPUTS 1-8** – optical TOSLINK type connectors each carrying ADAT-format digital audio bitstreams, with eight, four or two audio channels per connector depending on sample rate, as above.
10. **S/PDIF OUTPUT** – phono (RCA) socket carrying two channels of digital audio in S/PDIF (professional) format.

11. **S/PDIF INPUT** – phono socket allowing connection of the S/PDIF output of a digital audio device. The two channels connected here may be placed on the RedNet network, as selected in RedNet Control. The S/PDIF signal connected here may also be used as the unit's sync source.
12. **WORD CLOCK INPUT** – a BNC socket for the connection of a dedicated word clock sync signal, typically derived from a studio master clock source used to sync all the interconnected digital audio units in the system.
13. **WORD CLOCK OUTPUT** – a BNC socket from which a word clock signal may be obtained for connection to other digital audio devices outside the RedNet network. The clock signal available here will be derived from the source selected in software, and confirmed on the RedNet 3's front panel by LED.
14. **ETHERNET** – RJ45 network socket. Use a standard computer network cable to connect this socket to a local Ethernet switch to connect the RedNet 3 to the RedNet network. The socket has integral LEDs which illuminate to indicate connection to an active network port, and network activity. See page 8 for connector details.
15. AC mains inlet – standard IEC receptacle for connection of AC mains. RedNet 3 has a 'Universal' PSU, enabling it to operate from any supply voltages between 100 V and 240 V.

## PHYSICAL CHARACTERISTICS

RedNet 3's dimensions are shown in the diagram below:

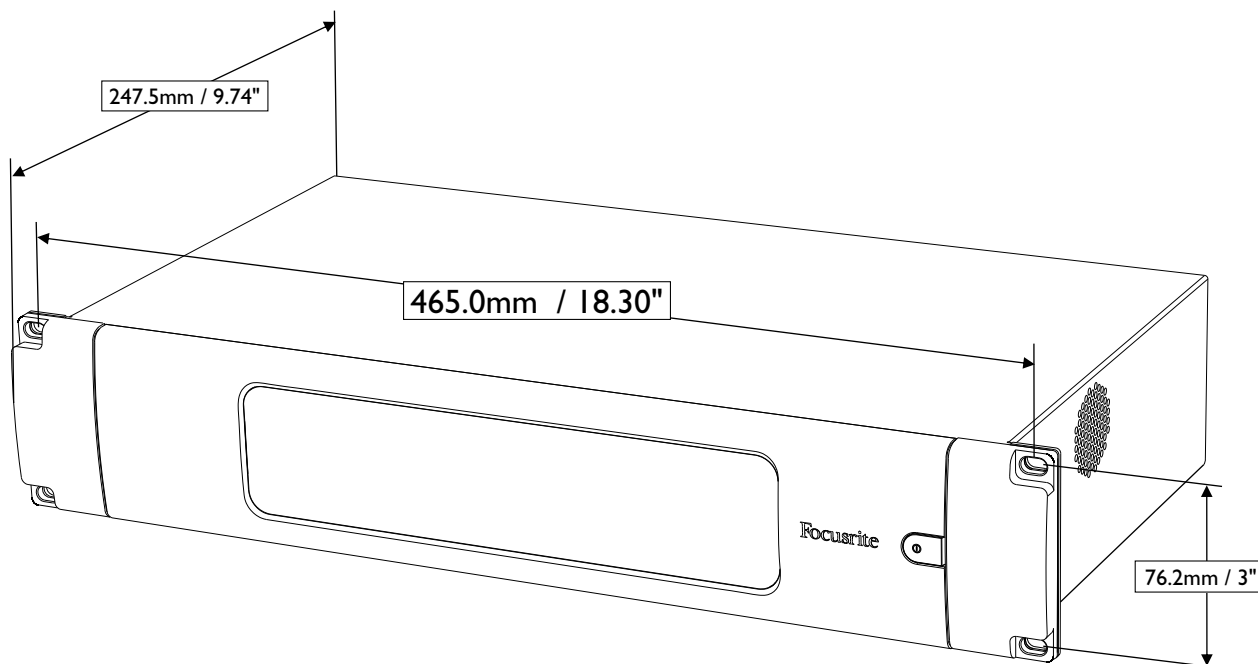

RedNet 3 requires 2U of vertical rackspace and at least 350 mm of rack depth, to allow for cables. RedNet 3 weighs 4.34 kg, and for installations in a fixed environment (e.g., a studio), the front panel mounting screws will provide adequate support. If the units are to be used in a mobile situation (e.g., flight-cased for touring, etc.), consideration should be given to using side support rails within the rack.

RedNet 3 generates no significant heat, and is cooled by natural convection. We recommend that the unit should not be used in locations where the ambient temperature is greater than 30°C (85° F).

Ventilation is via slots in the enclosure at both sides. Do not mount RedNet 3 immediately above any other equipment which generates significant heat, for example, a power amplifier. Also, ensure that when mounted in a rack, the side vents are not obstructed.

## POWER REQUIREMENTS

RedNet 3 is mains-powered. It incorporates a 'Universal' power supply, which can operate on any AC mains voltage from 100 V to 240 V. The AC connection is made via a standard 3-pin IEC connector on the rear panel. A mating IEC cable is supplied with the unit, which should be terminated with a mains plug of the correct type for your country.

The maximum rated AC power consumption of RedNet 3 is 30 VA.



Please note that there are no user-replaceable fuses in RedNet 3, or other user-replaceable components of any type. Please refer all servicing issues to the Customer Support Team (see "Customer Support and Unit Servicing" on page 55).

## First Use and Firmware Updates

Your RedNet 3 will require a firmware update when it is first installed and switched on. Firmware updates are initiated and handled automatically by the RedNet Control application. It is important that the firmware update procedure is not interrupted, either by switching off the RedNet 6 or the computer on which RedNet Control is running or disconnecting either from the network.

From time to time Focusrite will release RedNet firmware updates with new versions of RedNet Control. We recommend keeping all RedNet units up to date with the latest firmware version supplied with each new version of RedNet Control.

## CONNECTORS

### AES/EBU digital audio input/output connector

Connector type: 25-pin female Dsub  
 Applies to: AES/EBU INPUTS/OUTPUTS  
 Standard: AES 59

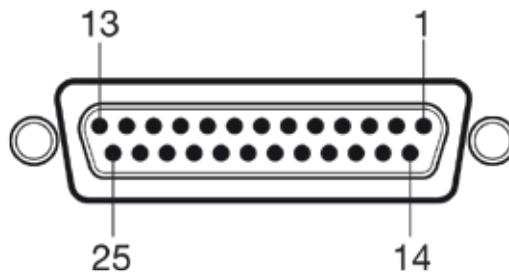

| Pin | Signal                         | Pin | Signal                         |
|-----|--------------------------------|-----|--------------------------------|
| 1   | AES/EBU Ch D output 'hot' (+)  | 14  | AES/EBU Ch D output 'cold' (-) |
| 2   | AES/EBU Ch D output screen     | 15  | AES/EBU Ch C output 'hot' (+)  |
| 3   | AES/EBU Ch C output 'cold' (-) | 16  | AES/EBU Ch C output screen     |
| 4   | AES/EBU Ch B output 'hot' (+)  | 17  | AES/EBU Ch B output 'cold' (-) |
| 5   | AES/EBU Ch B output screen     | 18  | AES/EBU Ch A output 'hot' (+)  |
| 6   | AES/EBU Ch A output 'cold' (-) | 19  | AES/EBU Ch A output screen     |
| 7   | AES/EBU Ch D input 'hot' (+)   | 20  | AES/EBU Ch D input 'cold' (-)  |
| 8   | AES/EBU Ch D input screen      | 21  | AES/EBU Ch C input 'hot' (+)   |
| 9   | AES/EBU Ch C input 'cold' (-)  | 22  | AES/EBU Ch C input screen      |
| 10  | AES/EBU Ch B input 'hot' (+)   | 23  | AES/EBU Ch B input 'cold' (-)  |
| 11  | AES/EBU Ch B input screen      | 24  | AES/EBU Ch A input 'hot' (+)   |
| 12  | AES/EBU Ch A input 'cold' (-)  | 25  | AES/EBU Ch A input screen      |
| 13  | n/c                            |     |                                |

| AES/EBU Ch | Audio channels |
|------------|----------------|
| A          | 1 & 2          |
| B          | 3 & 4          |
| C          | 5 & 6          |
| D          | 7 & 8          |

### Ethernet connector

Connector type: RJ-45 receptacle  
 Applies to: ETHERNET  
 Cable type: CAT 5e or CAT 6

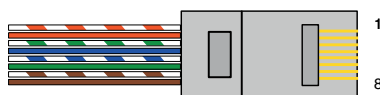

| Pin | Cat 6 Core     |
|-----|----------------|
| 1   | White + Orange |
| 2   | Orange         |
| 3   | White + Green  |
| 4   | Blue           |
| 5   | White + Blue   |
| 6   | Green          |
| 7   | White + Brown  |
| 8   | Brown          |

### Word Clock I/O (Ext sync)

Connector type: 2 x 75 ohm BNC sockets  
 Applies to: WORD CLOCK INPUT and OUTPUT

### S/PDIF I/O (Digital audio Chs 1 and 2)

Connector type: 2 x phono (RCA) sockets  
 Applies to: S/PDIF INPUT and OUTPUT

### ADAT I/O (Digital audio Channels 1 – 64)

Connector type: TOSLINK  
 Applies to: OPTICAL INPUTS 1-8 and OUTPUTS 1-8

## PERFORMANCE SPECIFICATIONS

| <b>Inputs</b>                               |  |
|---|--|
| AES/EBU inputs                              | 8 channels, with switchable SRC  |
| AES/EBU connector                           | 25-way female Dsub, wired to AES 59 (combined I/O)   |
| ADAT inputs                                 | 32 channels @ 44.1 / 48 / 88.2 / 96 kHz sample rate; 16 channels @ 192 kHz   |
| ADAT connectors                             | TOSLINK lightguides x 8  |
| S/PDIF input                                | 2 channels, with switchable SRC 44.1 to 192 kHz  |
| S/PDIF connector                            | Phono (RCA) socket   |
| <b>AES/EBU Input Sample Rate Converters</b> |  |
| Input sample rate range                     | 32 to 216 kHz  |
| Gain error                                  | -0.3 dB  |
| Dynamic Range                               | > 138 dB (-60 dBFS method)   |
| THD+N                                       | < -130 dB (0.00003%); 0 dBFS input   |
| <b>Outputs</b>                              |  |
| AES/EBU outputs                             | 8 channels, sync-locked to RedNet system sample rate   |
| AES/EBU connector                           | See "Inputs"   |
| ADAT outputs                                | 32 channels @ 44.1 / 48 / 88.2 / 96 kHz sample rate; 16 channels @ 192 kHz   |
| ADAT connectors                             | TOSLINK lightguides x 8  |
| S/PDIF output                               | 2 channels, sync-locked to RedNet system sample rate   |
| S/PDIF connector                            | Phono (RCA) socket   |
| <b>Operating Modes</b>                      |  |
| AES/EBU mode                                | AES/EBU inputs – Chs. 1 to 8; ADAT inputs – Chs. 9 to 32*; AES/EBU outputs – Chs. 1 to 8; ADAT outputs – Chs. 1 to 32* |
| ADAT mode                                   | ADAT inputs – Chs. 1 to 32*; AES/EBU outputs – Chs. 1 to 8; ADAT outputs – Chs. 1 to 32*                               |
| <b>Digital Performance</b>                  |  |
| Supported sample rates                      | 44.1 / 48 / 88.2 / 96 / 192 kHz  |
| Clock sources                               | Local or from network master device  |
| Local clock sources                         | Internal, Word Clock input, AES input 1, ADAT input 1, S/PDIF input  |
| External word clock range                   | Sample rate $\pm 7.5\%$  |
| <b>Power</b>                                |  |
| PSU   | Internal, 100 - 240 V, consumption 30 VA   |

\* Sample rate dependent – max. 16 channels at 192 kHz

| <b>Front Panel Indicators</b> |                                     |
|-------------------------------|-------------------------------------|
| Power                         | Green                               |
| Network connected             | Green                               |
| Sync lock                     | Green                               |
| Sample rate                   | Yellow x 5                          |
| Clock source                  | Yellow x 5                          |
| Signal present                | Green x 16; illuminate at -128 dBFS |

# REDNET 4

## UNIT CONNECTIONS AND FEATURES

### RedNet 4 - Front Panel

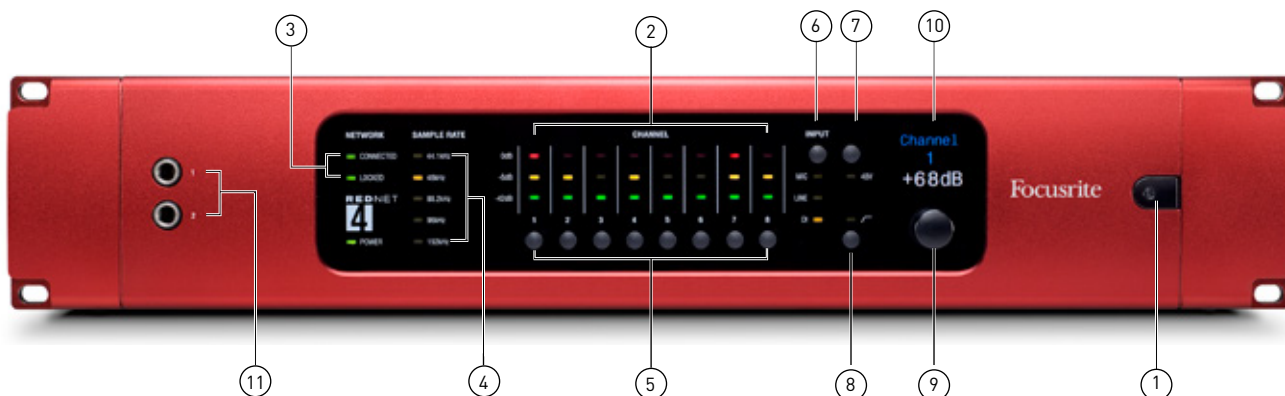

1. AC Power switch
2. Individual LEDs indicating signal level at each analogue input:
  - Green – signal level above -42 dBFS
  - Yellow – signal level above -6 dBFS
  - Red – signal level has reached 0 dBFS
3. **NETWORK** status flags – two green LEDs confirming network status:
  - **CONNECTED** – illuminates when the unit is connected to an active Ethernet network
  - **LOCKED** – illuminates when a valid clock sync is received via the network
4. **SAMPLE RATE** indication – five yellow LEDs; only one of these (**44.1 kHz, 48 kHz, 88.2 kHz, 96 kHz, 192 kHz**) will be lit at a time, to confirm the sample rate that the system is running at.
5. **CHANNEL 1 – 8** select buttons – these push-buttons select the input channel whose settings are to be adjusted with the controls [6], [7], [8] and [9] described below. These settings can also be controlled from the RedNet Control software application. The channel selected is confirmed on the OLED display[10]. Note that it is also possible to link pairs of channels (1 & 2, 3 & 4, etc.) from RedNet Control, to facilitate the use of stereo sources. The two channels may have different gains if wished (useful if using MS mics), in which case the OLED displays the gain offset.
6. **INPUT** – this button scrolls through the input options for each channel – **MIC, LINE** or **DI** (Inputs 1 and 2 only). A yellow LED indicates the input selected.
7. **48V** – this button enables 48 V phantom power at the microphone input for the selected channel.



8.  – switches an (analogue) high pass filter into circuit in the selected channel. The filter has a -3 dB point of 75 Hz and a slope of 18 dB/octave.
9. **GAIN** – a rotary encoder which adjusts the gain of the input channel between 0 and +63 dB in MIC mode, -12 and +42 dB in LINE mode and +14 and +68 dB in DI mode. The gain is indicated by the OLED numeric display [10].
10. OLED display – indicates the channel currently selected for adjustment and gain setting.
11. DI Inputs **1** and **2** – two ¼” jack sockets for direct connection of musical instruments.

## RedNet 4 - Rear Panel



12. **ANALOGUE INPUTS 1-8** – 25-pin female Dsub connector for connecting up to 8 line level sources to the RedNet system. All inputs are electronically balanced. See page 27 for connector details.
13. **MICROPHONE INPUTS 1-8** – eight 3-pin female XLR sockets for connecting microphones to the RedNet system via the built-in Focusrite mic preamps. All inputs are electronically balanced and each may have 48 V phantom power enabled. See page 28 for connector details.
14. **ETHERNET** – RJ45 network socket. Use a standard computer network cable to connect this socket to a local Ethernet switch to connect the RedNet 4 to the RedNet network. The socket has integral LEDs which illuminate to indicate connection to an active network port, and network activity. See page 28 for connector details.
15. AC mains – standard IEC receptacle for connection of AC mains. RedNet 4 has a 'Universal' PSU, enabling it to operate from any supply voltage between 100 V and 240 V.

## PHYSICAL CHARACTERISTICS

RedNet 4's dimensions are shown in the diagram below:

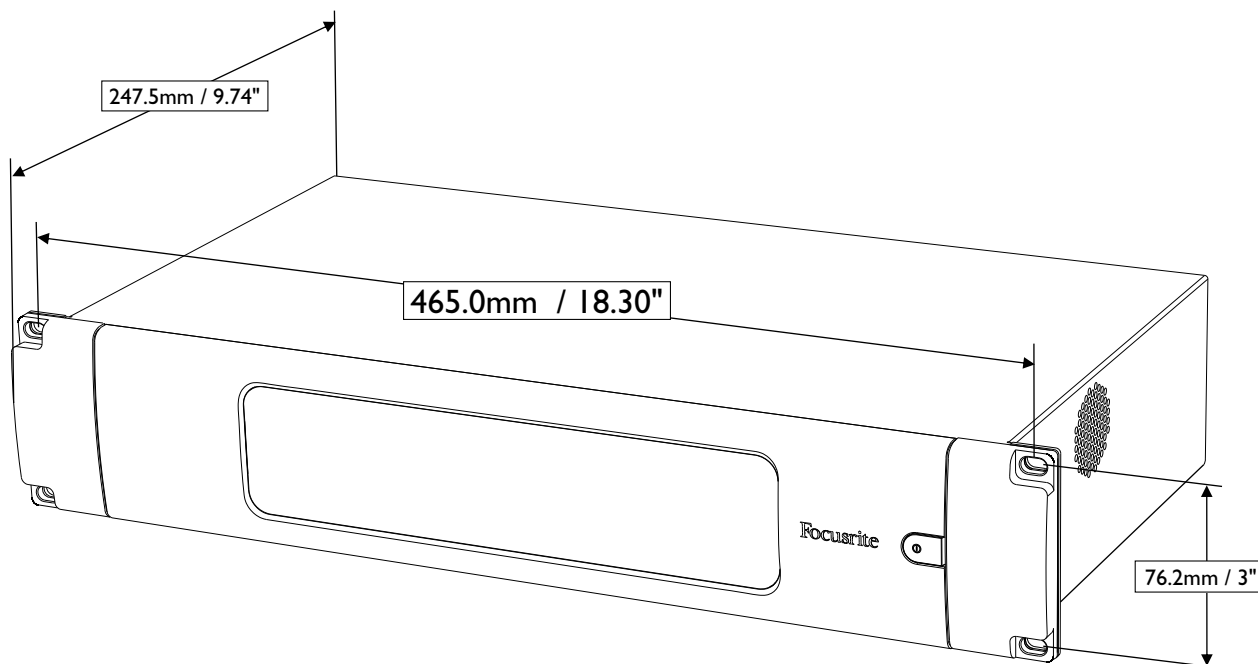

RedNet 4 requires 2U of vertical rackspace and at least 350 mm of rack depth, to allow for cables. RedNet 4 weighs 4.04 kg, and for installations in a fixed environment (e.g., a studio), the front panel mounting screws will provide adequate support. If the units are to be used in a mobile situation (e.g., flight-cased for touring, etc.), consideration should be given to using side support rails within the rack.

RedNet 4 generates no significant heat, and is normally cooled by natural convection, though an internal cooling fan is fitted. We recommend that the unit should not be used in locations where the ambient temperature is greater than 30°C (85°F). However, if this is unavoidable, the fan can be turned on and off from RedNet Control.

Ventilation is via slots in the enclosure at both sides. Do not mount RedNet 4 immediately above any other equipment which generates significant heat, for example, a power amplifier. Also, ensure that when mounted in a rack, the side vents are not obstructed.

## POWER REQUIREMENTS

RedNet 4 is mains-powered. It incorporates a 'Universal' power supply, which can operate on any AC mains voltage from 100 V to 240 V. The AC connection is made via a standard 3-pin IEC connector on the rear panel. A mating IEC cable is supplied with the unit, which should be terminated with a mains plug of the correct type for your country.

The AC power consumption of RedNet 4 is 45 VA.



Please note that there are no fuses in RedNet 4, or other user-replaceable components of any type. Please refer all servicing issues to the Customer Support Team (see "Customer Support and Unit Servicing" on page 55).

## First Use and Firmware Updates

Your RedNet 4 will require a firmware update when it is first installed and switched on. Firmware updates are initiated and handled automatically by the RedNet Control application. It is important that the firmware update procedure is not interrupted, either by switching off the RedNet 6 or the computer on which RedNet Control is running or disconnecting either from the network.

From time to time Focusrite will release RedNet firmware updates with new versions of RedNet Control. We recommend keeping all RedNet units up to date with the latest firmware version supplied with each new version of RedNet Control.

## CONNECTORS

### 8-channel analogue line input connector

Connector type: 25-pin female Dsub  
 Applies to: ANALOGUE INPUTS 1-8  
 Standard: AES 59 (AKA Tascam wiring)

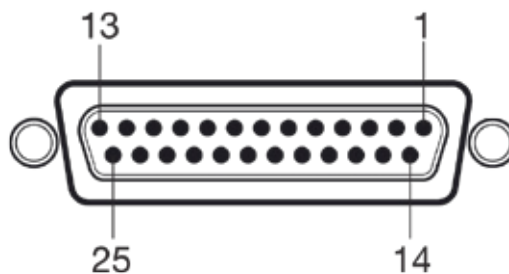

| Pin | Signal         |  | Pin | Signal          |
|-----|----------------|--|-----|-----------------|
| 1   | Ch 8 'hot' (+) |  | 14  | Ch 8 'cold' (-) |
| 2   | Ch 8 screen    |  | 15  | Ch 7 'hot' (+)  |
| 3   | Ch 7 cold (-)  |  | 16  | Ch 7 screen     |
| 4   | Ch 6 'hot' (+) |  | 17  | Ch 6 'cold' (-) |
| 5   | Ch 6 screen    |  | 18  | Ch 5 'hot' (+)  |
| 6   | Ch 5 cold (-)  |  | 19  | Ch 5 screen     |
| 7   | Ch 4 'hot' (+) |  | 20  | Ch 4 'cold' (-) |
| 8   | Ch 4 screen    |  | 21  | Ch 3 'hot' (+)  |
| 9   | Ch 3 cold (-)  |  | 22  | Ch 3 screen     |
| 10  | Ch 2 'hot' (+) |  | 23  | Ch 2 'cold' (-) |
| 11  | Ch 2 screen    |  | 24  | Ch 1 'hot' (+)  |
| 12  | Ch 1 cold (-)  |  | 25  | Ch 1 screen     |
| 13  | n/c            |  |     |                 |

Microphone inputs

Connector type: 3-pin female XLR  
 Applies to: MICROPHONE INPUTS

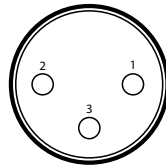

Rear (solder side) of mating male connector

| Pin | Signal            |
|-----|-------------------|
| 1   | Screen            |
| 2   | Signal 'hot' (+)  |
| 3   | Signal 'cold' (-) |

Ethernet connector

Connector type: RJ-45 receptacle  
 Applies to: ETHERNET  
 Cable type: CAT 5e or CAT 6

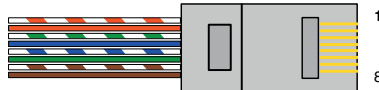

| Pin | Cat 6 Core     |
|-----|----------------|
| 1   | White + Orange |
| 2   | Orange         |
| 3   | White + Green  |
| 4   | Blue           |
| 5   | White + Blue   |
| 6   | Green          |
| 7   | White + Brown  |
| 8   | Brown          |

## PERFORMANCE SPECIFICATIONS

| Microphone Inputs                     |   |
|---------------------------------------|---|
| Gain range                            | 0 dB; 8 to 63 dB in 1 dB steps  |
| Type                                  | Classic ISA-based, electronically balanced, $Z_{in} = 2.4$ kohms                |
| Max. input level                      | +16 $\pm$ 0.5 dBu; min. gain for 0 dBFS, $R_s = 150$ ohms, pad out              |
| Min. input level                      | -47 $\pm$ 0.5 dBu; max. gain for 0 dBFS, $R_s = 150$ ohms, pad out              |
| Frequency response                    | 20 Hz – 55 kHz $\pm$ 0.1 dB (-3 dB @ 80 kHz, $f_s = 192$ kHz); $R_s = 150$ ohms |
| THD+N                                 | < 0.0007% @ -1 dBFS; +15 dBu input, $R_s = 150$ ohms, 20 Hz – 22 kHz            |
| Noise                                 | EIN -128 dB; 60 dB gain, $R_s = 150$ ohms, 20 Hz – 22 kHz                       |
| Phantom power                         | 48 V, independently switchable per-channel                                      |
| Signal-to-noise ratio                 | 119 dB 'A'-weighted; $R_s = 150$ ohms   |
| Line Inputs                           |   |
| Gain range                            | -12 to 42 dB in 1 dB steps  |
| Max. input level                      | +24 $\pm$ 0.5 dBu; min. gain for 0 dBFS   |
| Min. input level                      | -30 $\pm$ 0.5 dBu; max. gain for 0 dBFS   |
| Frequency response                    | 20 Hz – 20 kHz $\pm$ 0.1 dB   |
| THD+N                                 | < 0.003% @ -1 dBFS; +23 dBu input, min.gain, 20 Hz – 22 kHz                     |
| Signal-to-noise ratio                 | 117 dB 'A'-weighted   |
| Instrument Inputs (Inputs 1 & 2 only) |   |
| Gain range                            | +14 to 68 dB in 1 dB steps  |
| Max. input level                      | +17 $\pm$ 0.5 dBu; min. gain for 0 dBFS   |
| Min. input level                      | -37 $\pm$ 0.5 dBu; max. gain for 0 dBFS, pad out                                |
| Frequency response                    | 20 Hz – 20 kHz $\pm$ 0.1 dB   |
| THD+N                                 | < 0.001% @ -1 dBFS; +9 dBu input, min.gain, 20 Hz – 22 kHz                      |
| Signal-to-noise ratio                 | 112 dB 'A'-weighted   |
| Analogue High-Pass Filters            |   |
| Selection                             | Independently switchable per-channel  |
| Frequency/slope                       | -6 dB @ 65 $\pm$ 3 Hz, 12 dB/octave   |
| Crosstalk                             |   |
| Input to input                        | <-80 dB (all other channels at 0 dBFS)  |
| Digital Performance                   |   |
| Supported sample rates                | 44.1 / 48 / 88.2 / 96 / 192 kHz   |
| Clock sources                         | Internal or from network master device  |

| <b>Power</b>                  |  |
|-------------------------------|--|
| PSU                           | Internal, Universal type, consumption 45 VA                    |
| <b>Front Panel Indicators</b> |  |
| Power                         | Green  |
| Network connected             | Green  |
| Sync lock                     | Green  |
| Sample rate                   | Yellow x 5   |
| Channel 1/2 source            | Yellow x 3 (mic/line/inst)                                     |
| Signal level                  | Green x 8 (-42 dBFS); Yellow x 8 (-6 dBFS); Red x 8 (overload) |
| Channel select buttons        | 8  |
| Channel function controls     | Input source, HPF, phantom power, Gain encoder                 |
| Channel display               | Colour OLED; channel number, input source, gain                |

# REDNET 5

## UNIT CONNECTIONS AND FEATURES

### RedNet 5 - Front Panel

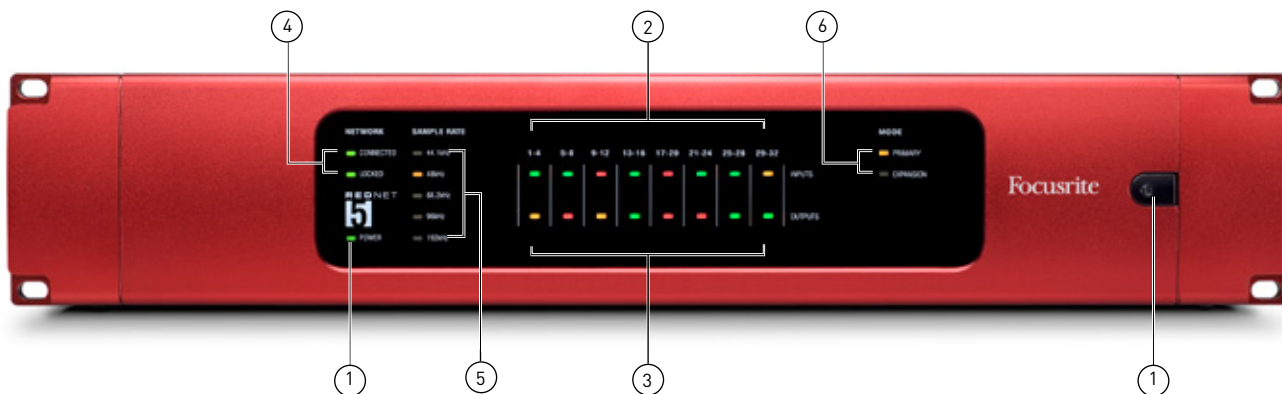

1. AC Power switch
2. **INPUTS** – inputs to the network (i.e., outputs from Pro Tools|HD\*). Eight tricolour LEDs indicating the signal level in four consecutively-numbered channels; the colour indicates the highest signal in the four. Individual LEDs indicating signal level at each analogue input:
  - Green: signal present
  - Amber: -6 dBFS
  - Red: 0 dBFS
3. **OUTPUTS** – outputs from the network (i.e., inputs to Pro Tools|HD\*). Eight LEDs indicating the signal level in the output channels; these function in the same manner as the input channel LEDs [2]
4. **NETWORK** status flags – two green LEDs confirming network status:
  - **CONNECTED** – illuminates when the unit is connected to an active Ethernet network
  - **LOCKED** – illuminates when a valid sync is received via the network or an external source
5. **SAMPLE RATE** indication – five yellow LEDs; only one of these (44.1 kHz, 48 kHz, 88.2 kHz, 96 kHz, 192 kHz) will be lit at a time, to confirm the sample rate that the system is running at.
6. **MODE** indicators – two yellow LEDs confirming the Pro Tools interface mode:
  - **PRIMARY** – the normal operating mode, in which RedNet 5 appears to Pro Tools as two external 16 channel interfaces.
  - **EXPANSION** – this mode should be selected from RedNet Control when the rear Panel EXPANSION port is in use. RedNet 5 will now appear to Pro Tools as a single 16 channel interface. This mode should also be used when RedNet 5 is connected to the expansion port of a 16 channel Pro Tools|HD device.
7. **POWER** LED

## RedNet 5 - Rear Panel



8. **PRIMARY** – DigiLink connector; use a standard Pro Tools I/O cable to link this to a port on the Pro Tools|HD/HDX/HD Native PCIe card, using the supplied DigiLink-to-Mini DigiLink adaptor cable if necessary.
9. **EXPANSION** – this can be used when RedNet 5 is operated in Expansion Mode to connect to another Pro Tools|HD I/O interface. In this mode, the RedNet 5 provides only 16 channels of I/O (16 in, 16 out) instead of 32.
10. **WORD CLOCK IN** – a BNC socket for the connection of a dedicated wordclock sync signal, typically derived from a studio master clock source used to sync all the interconnected digital audio units in the system.
11. **WORD CLOCK OUT** – a BNC socket from which a wordclock signal may be obtained for connection to other digital audio devices outside the RedNet network. The clock signal available here will be derived from the source selected in software, and may be at the sample rate in use, or at the 'base' sample rate of 44.1 kHz or 48 kHz.
12. **LOOP SYNC IN and OUT** – two BNC sockets which should be used for sync interconnection when standard Pro Tools I/O units also form part of the system. Connect the LOOP SYNC OUT of one RedNet 5 unit to the LOOP SYNC IN of a Pro Tools|HD I/O interface, in a standard daisy-chain manner. See page 40 for further LOOP SYNC connection details.
13. **ETHERNET** – RJ45 network socket. Use a Cat5e or Cat6 network cable to connect this socket to a local Ethernet switch to connect the RedNet 5 to the RedNet network. The socket has integral LEDs which illuminate to indicate connection to an active network port, and network activity. See page 40 for connector details.
14. **AC mains inlet** – standard IEC receptacle for connection of AC mains. RedNet 5 has a 'Universal' PSU, enabling it to operate from any supply voltages between 100 V and 240 V.



## PHYSICAL CHARACTERISTICS

RedNet 5's dimensions are shown in the diagram below:

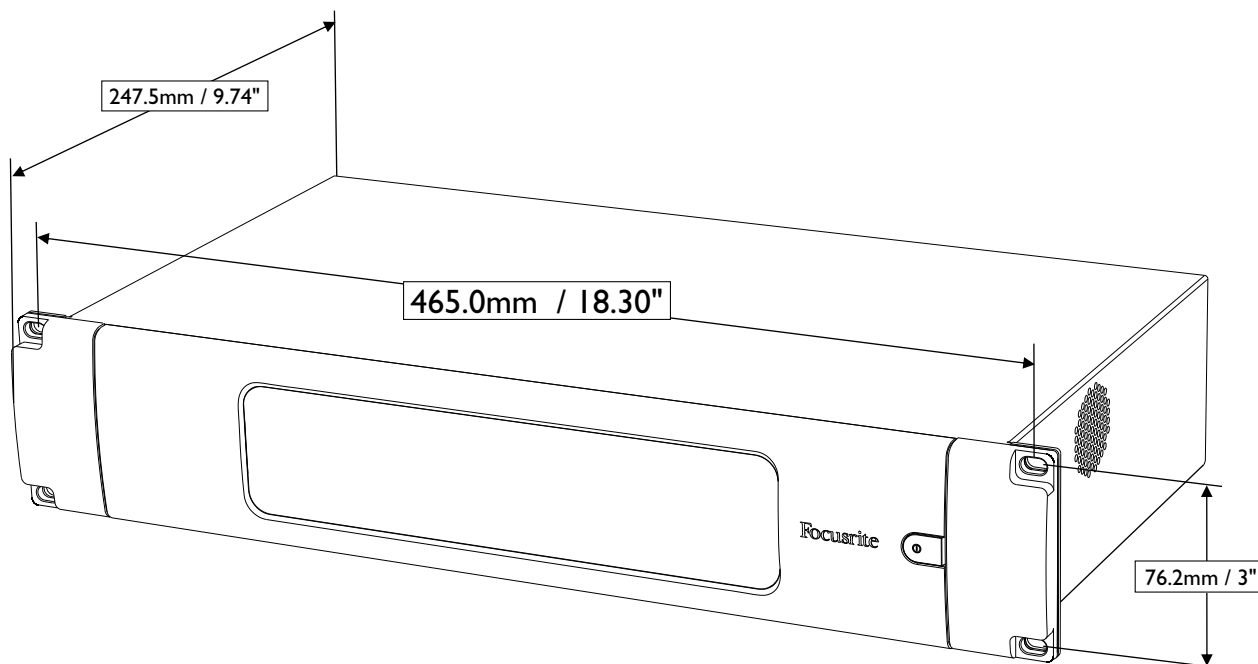

RedNet 5 requires 2U of vertical rackspace and at least 350 mm of rack depth, to allow for cables. RedNet 5 weighs 4.6 kg, and for installations in a fixed environment (e.g., a studio), the front panel mounting screws will provide adequate support. If the units are to be used in a mobile situation (e.g., flight-cased for touring, etc.), consideration should be given to using side support rails within the rack.

RedNet 5 generates no significant heat, and is cooled by natural convection.

Ventilation is via slots in the enclosure at both sides. Do not mount RedNet 5 immediately above any other equipment which generates significant heat, for example, a power amplifier. Also, ensure that when mounted in a rack, the side vents are not obstructed.

## POWER REQUIREMENTS

RedNet 5 is mains-powered. It incorporates a 'Universal' power supply, which can operate on any AC mains voltage from 100 V to 240 V. The AC connection is made via a standard 3-pin IEC connector on the rear panel. A mating IEC cable is supplied with the unit, which should be terminated with a mains plug of the correct type for your country.

The AC power consumption of RedNet 5 is 45 VA.



Please note that there are no fuses in RedNet 5, or other user-replaceable components of any type. Please refer all servicing issues to the Customer Support Team (see page 55).

## First Use and Firmware Updates

Your RedNet 5 will require a firmware update when it is first installed and switched on. Firmware updates are initiated and handled automatically by the RedNet Control application. It is important that the firmware update procedure is not interrupted, either by switching off the RedNet 6 or the computer on which RedNet Control is running or disconnecting either from the network.

From time to time Focusrite will release RedNet firmware updates with new versions of RedNet Control. We recommend keeping all RedNet units up to date with the latest firmware version supplied with each new version of RedNet Control.

## INTERFACING TO PRO TOOLS

RedNet 5 units are connected to a Pro Tools|HD/HDX system in the same manner as Avid® Pro Tools|HD I/O audio interfaces, using standard DigiLink cables (not supplied).

A Rednet 5 provides 32 inputs and 32 outputs, compared to the 16 inputs and 16 outputs provided by Pro Tools|HD I/O audio interfaces. This means that each RedNet 5 appears to the Pro Tools system as two 16 channel I/O units.

### **Pro Tools|HD:**

Connect each RedNet 5's rear panel PRIMARY port to a DigiLink connector on the Pro Tools|HD system. Each Pro Tools|HD PCI/PCIe card has one DigiLink port (giving the card a capacity of 32 inputs and 32 outputs), thus one RedNet 5 may be connected to each card. A maximum of three RedNet 5s may be connected, giving a total input and output capability of 96 inputs and 96 outputs.

### **Pro Tools|HDX:**

Connect each RedNet 5's rear panel PRIMARY port to a Mini DigiLink connector on the Pro Tools|HDX system. Use the DigiLink-to-Mini DigiLink adaptor supplied with each RedNet 5 to complete the interconnection. Each Pro Tools|HDX card has two Mini DigiLink ports (giving the card a capacity of 64 inputs and 64 outputs), thus two RedNet 5s may be connected to each card. A maximum of six RedNet 5s may be connected, giving a total input and output capability of 192 inputs and 192 outputs.

### **Pro Tools|Native:**

Connect each RedNet 5's rear panel PRIMARY port to a Mini DigiLink connector on the Pro Tools HD|Native card or Pro Tools HD|Native Thunderbolt box. Use the supplied DigiLink-to-Mini DigiLink adaptor to complete the interconnection. Each Pro Tools|HD Native system can be connected to up to two RedNet 5s giving a total channel count of up to 64 inputs and 64 outputs.

The following diagrams show a single RedNet 5 connected to a single Pro Tools card; an HDX system requires the supplied DigiLink-to-Mini DigiLink adaptor:

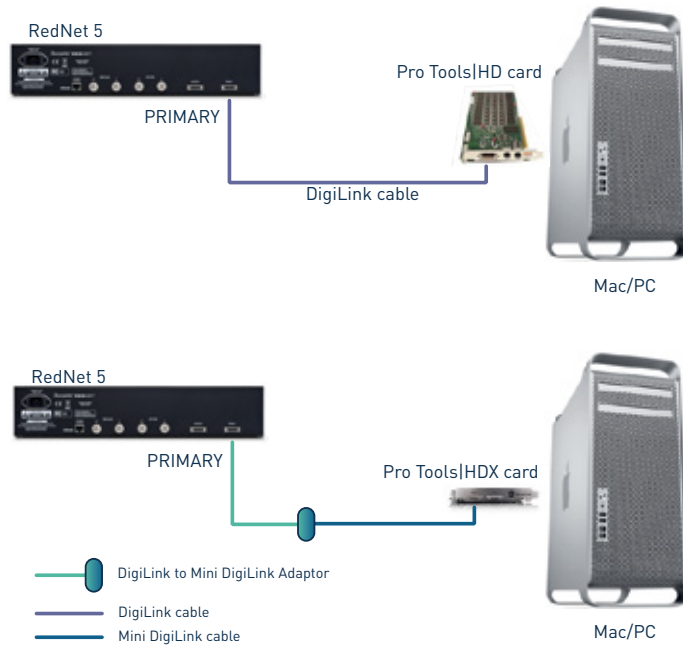

The diagrams below show two different methods of connecting two RedNet 5 units to a Pro Tools|HDX system; the only difference for a Pro Tools|HD system would be that the adaptor cable may be omitted:

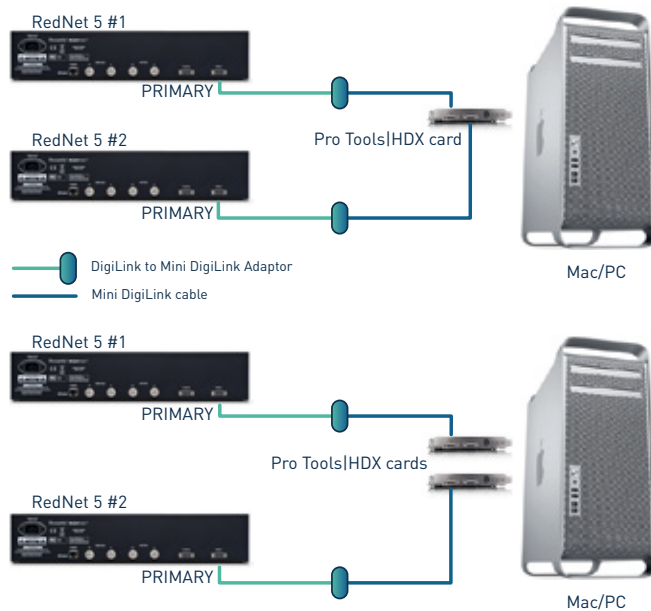

If multiple RedNet 5s are in use, each is linked to a separate port on the Pro Tools cards. HDX System shown for simplicity:

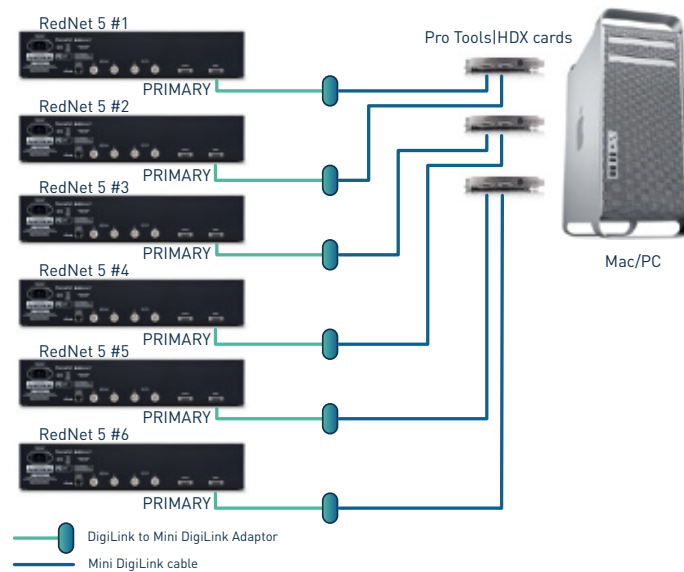

## PRO TOOLS SETUP

On the Pro Tools Hardware Setup page (click **Setup > Hardware**), select each RedNet 5 unit in turn and click the **Set to Default** button. This will ensure that the RedNet 5 is correctly configured for use with Pro Tools. Note that this action is not required when using RedNet 5 for the first time, as the unit was correctly pre-configured at time of manufacture.

### Sample Rate

RedNet 5 units will use the same sample rate that the Pro Tools session is running at. It is important that any devices routed to or from RedNet 5 are also set to the same sample rate. In simple systems, where the entire network is running at the same sample rate, RedNet Control can be used to globally change the sample rate of all units. If a more complex system is in use, where different units are running at different sample rates, please ensure that the units' sample rates are correctly set using Dante Controller.

### Using RedNet 5 with other Pro Tools|HD interfaces

RedNet 5 interfaces may be freely intermixed with other Pro Tools|HD I/O audio interfaces. However, it is important to remember that each Pro Tools|HD I/O audio interface allows for 16 channels bi-directionally, whereas a RedNet 5 allows for 32 channels.

In most situations, RedNet 5 will be connected directly to a DigiLink port on the Pro Tools|HD or HDX card and will be used in Primary Mode (full 32 channel operation). However, if a free port is not available, then RedNet 5 can be used in Expansion Mode. This mode reduces the available channels in RedNet 5 to 16 and permits the connection of an existing 16 channel Pro Tools|HD interface to its EXPANSION port; therefore providing a combined total of 32 channels at the HD or HDX card's port. This is achieved by selecting Expansion Mode in RedNet Control.

When connecting devices in Expansion Mode, the Pro Tools|HD card should be connected to the PRIMARY port of the first interface. Its Expansion port should then connect to the PRIMARY port of the second interface. See diagram on following page:

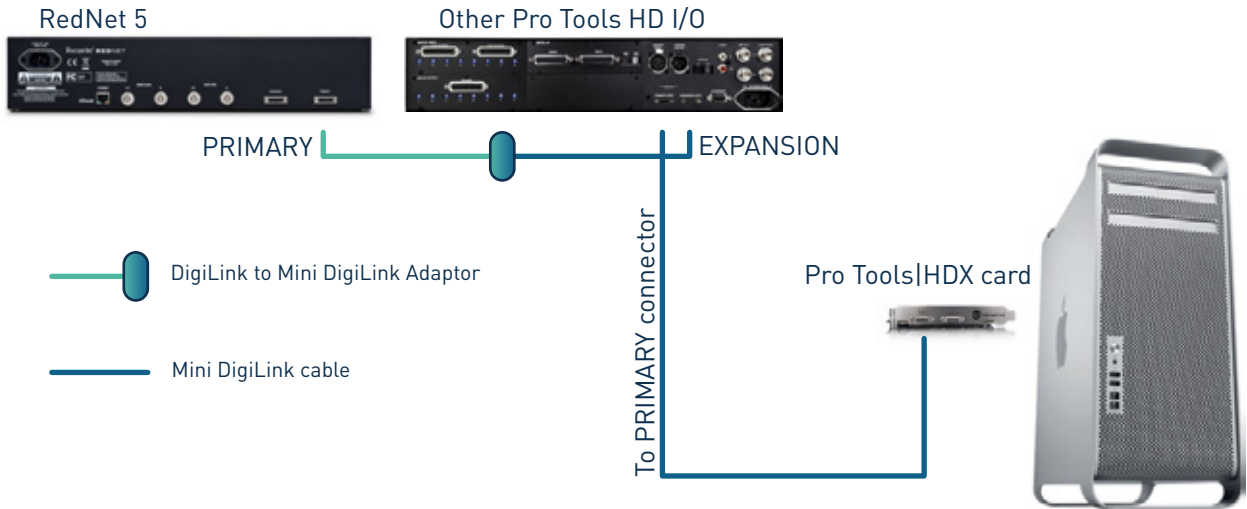

## SYNCHRONISATION AND CLOCKING

**IMPORTANT** - The diagrams in the preceding section only illustrate the DigiLink interconnections between system elements. However, consideration must also be given to word clock source and routing. It is very important to arrange word clock routing correctly when using multiple I/O units.

The rules for setting clock source depend on the complexity of the system being implemented. They are explained by the following four examples, which collectively cover almost every likely interconnection situation.

### Situation 1 - Single Pro Tools system with RedNet 5s only:

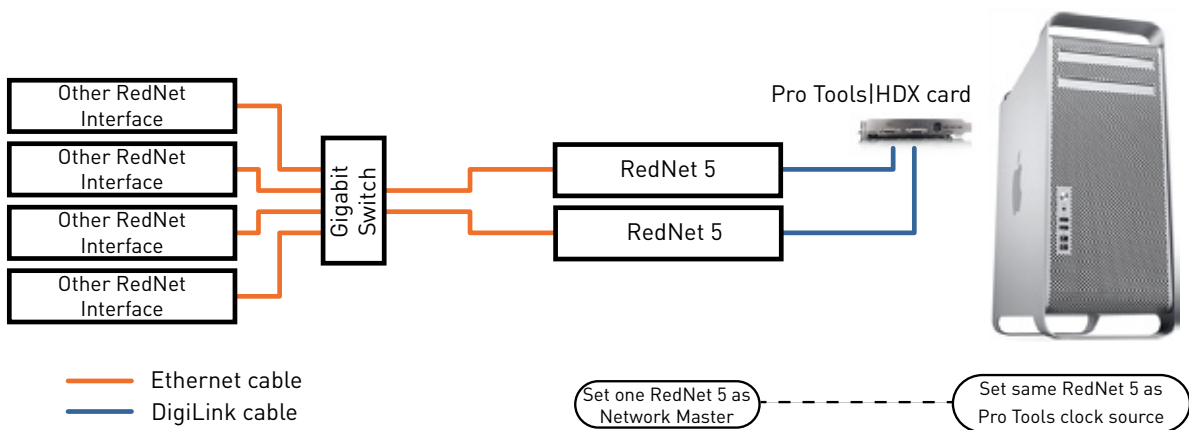

In this situation, one or more RedNet 5 units are the only audio interfaces on the Pro Tools system.

- Any Dante unit on the network may be selected through Dante Controller as the network master. If possible it is recommended that one of the RedNet 5 units is network master.
- In Pro Tools, any of the RedNet 5s may be selected to be the clock source, but it is recommended that the unit set as the RedNet network master in Step 1 should also be the Pro Tools clock source.

**Situation 2 – Single Pro Tools system with both RedNet 5s and other Pro Tools interfaces**

Pro Tools|HD I/O audio interfaces may be used as audio I/O on the same Pro Tools system as RedNet 5s. Choose the audio interface you wish to be the clock source. This may be either a RedNet 5 or a Pro Tools audio interface.

**If a RedNet 5 is to be the clock source:**

- It is recommended that the same Rednet 5 is set in RedNet Control as the RedNet network master .
- Connect a BNC cable between the LOOP SYNC OUT of any of the RedNet 5s to the LOOP SYNC IN of one of the Pro Tools audio interfaces.
- Connect additional BNC cables between the LOOP SYNC OUT of the 'first' Pro Tools|HD I/O audio interface and the other Pro Tools interfaces, in the usual 'daisy-chain' manner.

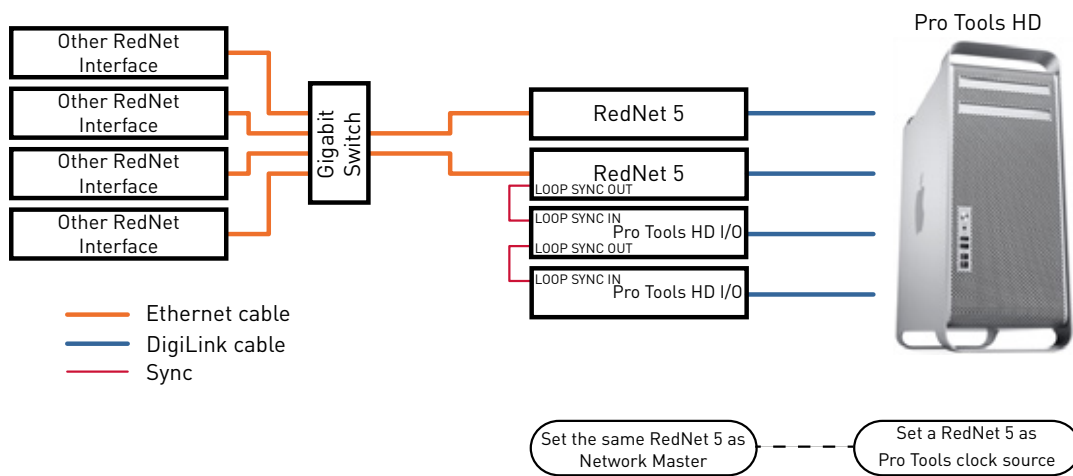

**If a Pro Tools|HD I/O audio interface is to be the clock source:**

- Connect a BNC cable between the LOOP SYNC OUT of one of the Pro Tools interfaces to the LOOP SYNC IN of one RedNet 5. No daisy-chaining is required, as any other RedNet 5s will be synchronised via their Ethernet connections.
- In RedNet Control, set the RedNet 5 in Step 1 as the network master.
- Also in RedNet Control, set the clock source for this same unit to “Loop Sync”.

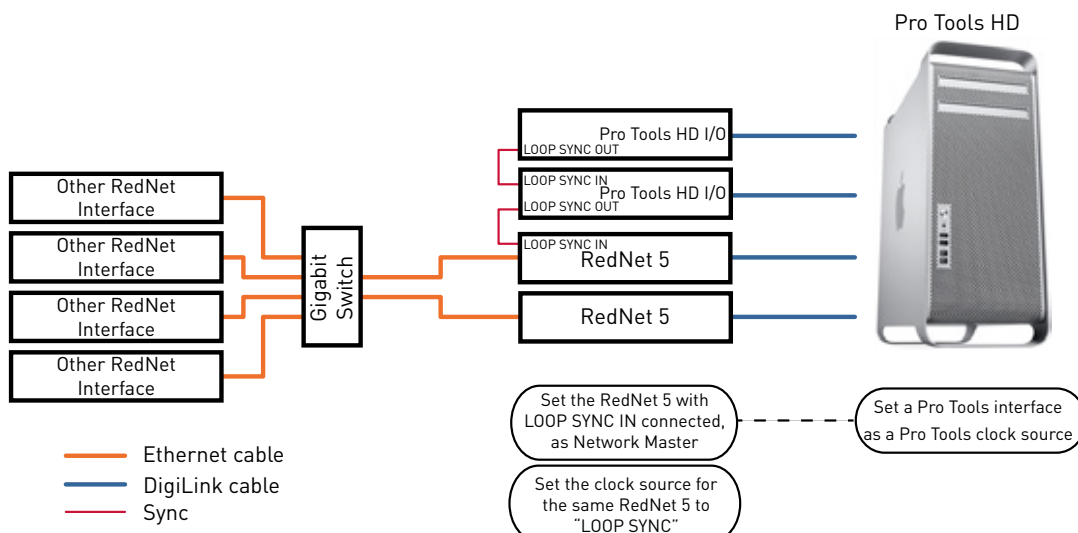

### Situation 3 – Single Pro Tools system with RedNet 5s (other Pro Tools interfaces optional), where another RedNet unit is the clock master

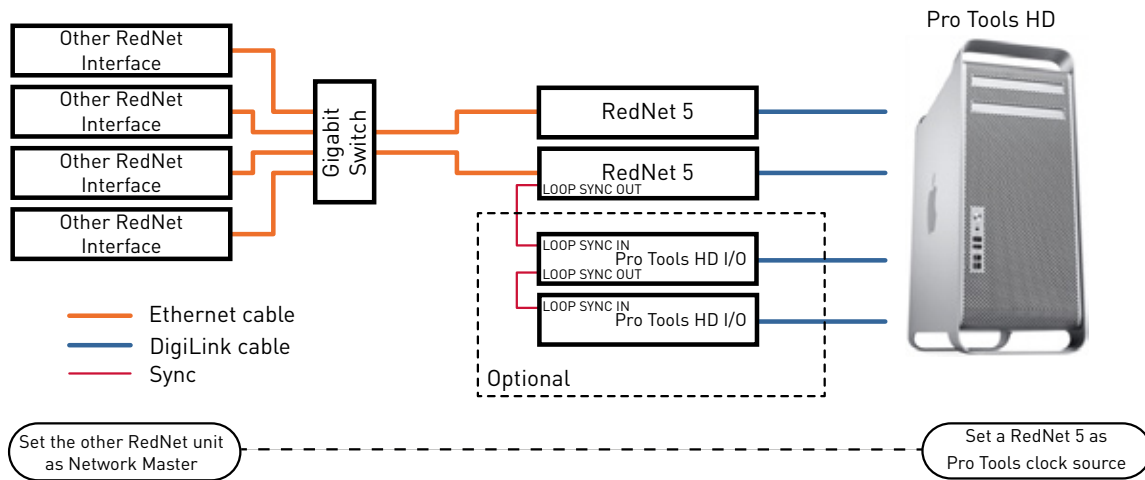

In this system, another RedNet interface on the RedNet network is the clock master (i.e., not a RedNet 5). For example, this situation might arise if there is also a RedNet 3 resolving its clock from an audio input or word clock input.

- In RedNet Control, set the relevant RedNet unit as the clock master in the Tools menu.
- A RedNet 5 unit must be selected as the Pro Tools clock source. In the Pro Tools **Hardware Setup** window, set **Clock Source** to **Internal** for one RedNet 5.
- If there are also non RedNet 5 Pro Tools interfaces in the system, connect LOOP SYNC OUT on one RedNet 5 to LOOP SYNC IN of a Pro Tools interface, and daisy-chain any subsequent units in the usual manner.

### Situation 4 – Multiple Pro Tools systems, each with RedNet 5s

The guiding rule here is:

- one of the Pro Tools systems may be configured as described for any of Situations 1, 2 or 3 above;
- all other Pro Tools systems must be set up as described in Situation 2, with one of the RedNet 5s on each being assigned as the Pro Tools clock master.

It is important to note that when more than one Pro Tools system is connected to the RedNet network, all audio routing must be conducted using Dante Controller instead of RedNet Control. For audio to be transferred between Pro Tools systems, all the systems must be set to run at the same sample rate.

## CONNECTORS

### Pro Tools interfaces

Connector type: 2 x DigiLink female  
 Applies to: PRIMARY, EXPANSION

### Ethernet connector

Connector type: RJ-45 receptacle  
 Applies to: ETHERNET  
 Cable type: CAT 5e or CAT 6

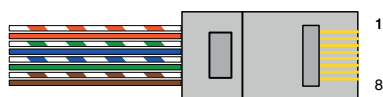

| Pin | Cat 6 Core     |
|-----|----------------|
| 1   | White + Orange |
| 2   | Orange         |
| 3   | White + Green  |
| 4   | Blue           |
| 5   | White + Blue   |
| 6   | Green          |
| 7   | White + Brown  |
| 8   | Brown          |

### Word Clock I/O (Ext sync)

Connector type: 2 x 75 ohm BNC sockets  
 Applies to: WORD CLOCK IN and OUT

### Loop Sync I/O

Connector type: 2 x 75 ohm BNC sockets  
 Applies to: LOOP SYNC IN and OUT



## PERFORMANCE SPECIFICATIONS

| <b>Digital Performance</b>    |   |
|-------------------------------|---|
| Supported sample rates        | 44.1 / 48 / 88.2 / 96 / 192 kHz   |
| Internal clock sources        | Local, Word clock input, Loop Sync  |
| External word clock range     | Sample rate $\pm 7.5\%$   |
| <b>Front Panel Indicators</b> |   |
| Power                         | Green   |
| Network connected             | Green   |
| Sync lock                     | Green   |
| Sample Rate                   | Yellow x 5  |
| Mode                          | Yellow x 2  |
| Signal present                | Tricolour x 16 (each LED represents four channels)<br>Green: signal present<br>Amber: -6 dBFS,<br>Red: 0 dBFS |
| <b>General</b>                |   |
| PSU                           | Internal, Universal type: 90–260 V<br>Consumption 30 VA   |
| Dimensions (W x H x D)        | 482 mm x 88 mm (2U) x 247.5 mm; 19in x 3.5in x 9.7in  |
| Weight                        | 4.61 kg; 10.17 lbs  |

# REDNET 6

## UNIT CONNECTIONS AND FEATURES

### RedNet 6 - Front Panel

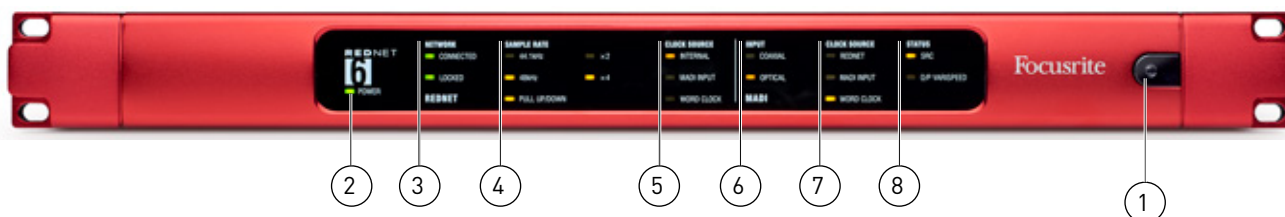

#### 1. AC Power Switch

#### 2. Power Indicator

#### 3. RedNet Network Status Indicators:

- **CONNECTED** – illuminates when the unit is connected to an active Ethernet network.
- **LOCKED** – illuminates when a valid sync signal is received from the network or the RedNet 6 unit is network master. When an incoming clock signal is invalid, the Locked indicator will flash to indicate that the unit has reverted to using its internal clock.

#### 4. RedNet Sample Rate Indicators:

- Five yellow indicators. The Indicators illuminate individually or in combination to indicate **44.1 kHz**, **48 kHz**, **x2 multiple** (of 44.1 or 48), **x4 multiple** (of 48) and sample rate **Pull Up/Down**. For example, for a 96kHz pull up/down setting, the 48kHz, x2 and Pull Up/Down indicators will illuminate.

#### 5. RedNet Clock Source Indicators:

When RedNet 6 is the clock master of the Dante network, one of the following indicators will illuminate.

- **INTERNAL** – illuminates to indicate the internal RedNet 6 sync clock is in use.
- **MADI INPUT** – illuminates to indicate an external MADI sync clock is in use.
- **WORD CLOCK** – illuminates to indicate an external Word Clock sync clock is in use.

#### 6. MADI Input Indicators:

If a selected input signal is either invalid or not present the input source indicator will flash.

- **COAXIAL** – illuminates to indicate that coaxial connection is operational.
- **OPTICAL** – illuminates to indicate that optical connection is operational.

## 7. MADI Clock Source Indicators:

- **REDNET** – illuminates to indicate the internal network sync clock is in use.
- **MADI INPUT** – illuminates to indicate an external MADI sync clock is in use.
- **WORD CLOCK** – illuminates to indicate an external Word Clock sync clock is in use.

## 8. MADI Status Indicators:

- **SRC** – illuminates to indicate sample rate conversion is active.
- **O/P VARISPEED** – illuminates to indicate output is operating in varispeed mode. The Output Varispeed indicator will flash to indicate that the output is out of MADI tolerance (beyond 1% of nominal), or if 'MADI follow Rx' is set and an invalid input is detected. Please note that when running in varispeed mode the channel count of the MADI output will be decreased. Please see the specifications table on page 48 for full details.

## Rear Panel



- AC mains** – standard IEC receptacle for connection of AC mains. RedNet 6 has a 'Universal' PSU, enabling it to operate from any supply voltages between 100 V and 240 V.
- Ethernet** – RJ45 network socket. Use a standard computer network cable to connect this socket to a local Ethernet switch to connect the RedNet 6 to the RedNet network. The socket has integral LEDs which illuminate to indicate connection to an active network port, and network activity. See page 46 for connector details.
- MADI Output** – BNC coaxial
- MADI Input** – BNC coaxial
- MADI Output** – Duplex SC optical (see p.48 for more details)
- MADI Input** – Duplex SC optical (see p.48 for more details)
- Word Clock Output** – BNC coaxial
- Word Clock Input** – BNC coaxial

**Note:** Word Clock Input can provide a clock source for the SRC or the network. Additionally when MADI and network are running synchronously Word Clock Input can accept a base-rate word clock signal.

## PHYSICAL CHARACTERISTICS

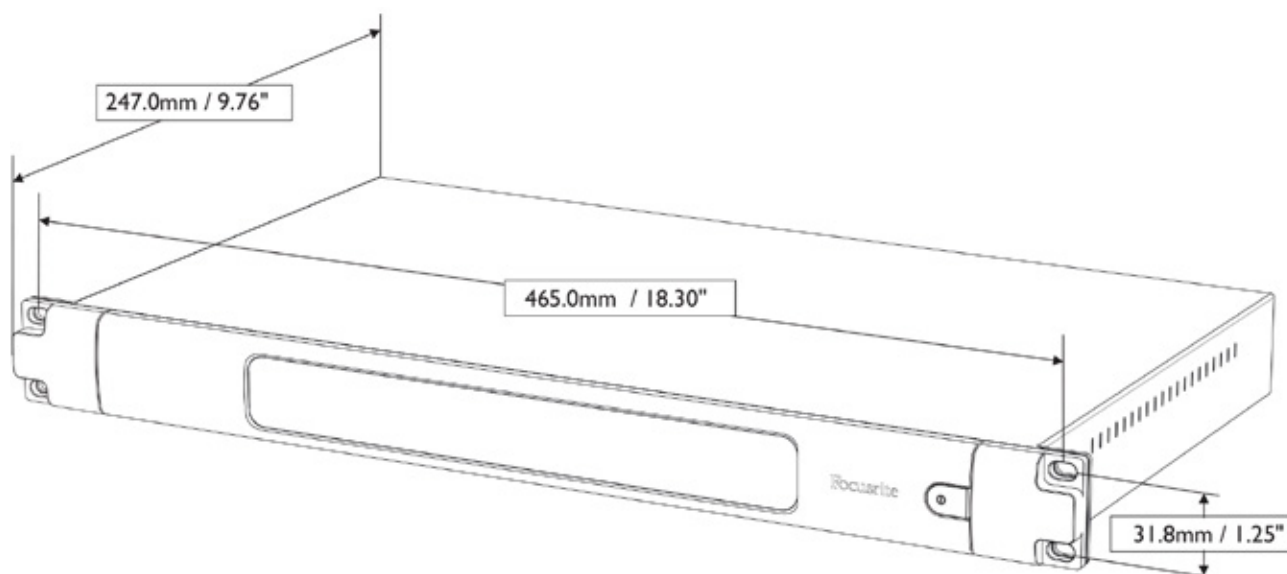

RedNet 6 dimensions are illustrated in the diagram above.

RedNet 6 requires 1U of vertical rack space and at least 350 mm of rack depth, to allow for cables. RedNet 6 weighs 3.74 kg and for installations in a fixed environment (e.g., a studio), the front panel mounting screws will provide adequate support. If the units are to be used in a mobile situation (e.g., flight-cased for touring, etc.), consideration should be given to using side support rails within the rack.

RedNet 6 generates little significant heat and is cooled by natural convection.

Ventilation is via slots in the enclosure at both sides. Do not mount RedNet 6 immediately above any other equipment which generates significant heat, for example, a power amplifier. Also, ensure that when mounted in a rack, the side vents are not obstructed.

## POWER REQUIREMENTS

RedNet 6 is mains-powered. It incorporates a 'Universal' power supply, which can operate on any AC mains voltage from 100 V to 240 V. The AC connection is made via a standard 3-pin IEC connector on the rear panel. A mating IEC cable is supplied with the unit, which should be terminated with a mains plug of the correct type for your country.

The AC power consumption of the RedNet 6 is 30VA.



Please note that there are no fuses in RedNet 6, or other user-replaceable components of any type. Please refer all servicing issues to the Customer Support Team (see "Customer Support and Unit Servicing" on page 55).

## REDNET 6 OPERATION

### First Use and Firmware Updates

Your RedNet 6 will require a firmware update when it is first installed and switched on. Firmware updates are initiated and handled automatically by the RedNet Control application. It is important that the firmware update procedure is not interrupted, either by switching off the RedNet 6 or the computer on which RedNet Control is running or disconnecting either from the network.

From time to time Focusrite will release RedNet firmware updates with new versions of RedNet Control. We recommend keeping all RedNet units up to date with the latest firmware version supplied with each new version of RedNet Control.

### Digital Clocking

RedNet 6 is able to operate across two separate clock domains:

- The RedNet network clock
- The MADI clock

Due to the inclusion of sample rate converters in the product, the two clock domains do not need to be synchronous so independent clock sources can be used.

Three potential clock sources are possible:

- Network (RedNet 6 can also act as network master clock)
- Word Clock In
- MADI Input

When sample rate conversion is enabled, the clock source of the MADI output and the RedNet 6 can be selected independently in the RedNet Control application.

When sample rate conversion is disabled, the MADI output will be synchronous with the RedNet network. In this case, the selection of clock source for the unit is selected under RedNet Clock Source in the RedNet Control application. If MADI and the Network are to run synchronously, the following rules must be followed:

- If Network is selected as the clock source, it is important that any device sending a MADI signal to RedNet 6 is also receiving a word clock signal from the RedNet 6 or another RedNet unit.
- If Word Clock In is selected as the clock source, any device which is sending a MADI signal to RedNet 6 must also receive a valid clock signal from the same source as RedNet 6

The RedNet 6 Word Clock Output may be switched via the RedNet Control application to output one of four clock signals:

- Network Clock
- Network Clock (base rate)
- MADI Input
- Word Clock Input

The RedNet 6 Word Clock input has a software selectable 75 ohm termination selected via the RedNet Control application.

## MADI Modes

RedNet 6 supports both varispeed and non-varispeed MADI modes. Non-varispeed mode enables up to 64 channels I/O at 48 kHz. Varispeed mode enables up to 56 channels I/O at 48kHz. The MADI input of RedNet 6 will automatically detect the channel count of incoming signals, meaning the user does not need to adjust any settings. When 'Follow Rx' (located in MADI Output menu) is set, the MADI output of RedNet 6 will automatically be set to match the incoming MADI signal.

The RedNet 6 MADI input select is auto sensing by default although manual override is provided in the RedNet Control application. When Auto mode is selected and both coaxial and optical inputs are present, RedNet 6 will automatically prefer the optical input. If the optical cable is removed from the RedNet 6 input, the unit will automatically switch to the coaxial input. If auto input is selected while no valid coaxial or optical input is present, both the optical and coaxial input indicators will flash.

The RedNet 6 MADI output has three varispeed states selectable in the RedNet Control application:

- Varispeed
- Fixed
- Follow MADI input

In addition to the varispeed states the RedNet 6 MADI output is capable of a range of sample rates. These can be selected in the RedNet Control application:

- Single (44.1 or 48 kHz)
- Dual (88.2 kHz or 96 kHz)
- Quad (176.4 or 192 kHz)
- Follow MADI input

When a MADI input is present, the MADI output of RedNet 6 will automatically match the MADI input.

## Pull Up and Pull Down Operation

RedNet devices are able to run with pull up or pull down sample rates in one of two ways:

- Locking to an external clock at the desired clock frequency
- Operating at a specified pull up or pull down percentage as selected in the Dante Controller application\*

\* Note: Not all RedNet devices currently support this mode of operation.

During 64 channel (i.e. non-varispeed mode) operation, MADI is not capable of operating at greater than approximately +1% of the nominal sample rate. This may become a problem when the network clock domain is pulled up beyond 1% of nominal. In this condition, the Output Varispeed indicator on the front panel will flash to indicate that the output is out of MADI tolerance. Therefore to continue generating a valid RedNet 6 MADI output it would be necessary to operate the MADI output in 56 channel (varispeed) mode, use sample rate conversion or reduce the network rate to within 1% of nominal sample rate.

## Sample Rate Converters

RedNet 6 has sample rate converters on both its inputs and outputs allowing the network and MADI domains to have sample rates which are independent of each other.

This can be particularly useful in post production environments where the network audio is pulled up or down, but it is necessary to have the MADI stream run at a base sample rate to interface, for example, with a mixing console. Engaging the RedNet 6 sample rate converters will however increase the overall latency of the device.

## CONNECTOR

### Ethernet connector

Connector type: RJ-45 receptacle  
Applies to: ETHERNET  
Cable type: CAT 5e or CAT 6

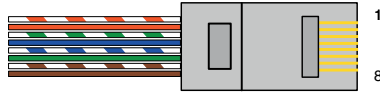

| Pin | Cat 6 Core     |
|-----|----------------|
| 1   | White + Orange |
| 2   | Orange         |
| 3   | White + Green  |
| 4   | Blue           |
| 5   | White + Blue   |
| 6   | Green          |
| 7   | White + Brown  |
| 8   | Brown          |

## PERFORMANCE SPECIFICATIONS

| <b>Word Clock</b>       |   |               |             |
|-------------------------|---|---------------|-------------|
| Connectors              | BNC 75Ω   |               |             |
| Output                  | 5V 75Ω DC-coupled   |               |             |
| Input                   | locks down to 0.2V AC-coupled (75Ω software switchable termination) |               |             |
| <b>MADI Coaxial</b>     |   |               |             |
| Electrical standard     | as per AES10:2008   |               |             |
| Recommended Cable       | 75Ω characteristic impedance  |               |             |
| Connector               | BNC 75Ω   |               |             |
| <b>MADI Optical</b>     |   |               |             |
| Optical Standard        | as per AES10:2008 (ISO/IEC 9314-3, FDDI, ANSI X3.166)               |               |             |
| Recommended Cable       | Multi-mode, Graded-index, 62.5μm core, 125μm cladding               |               |             |
| Connector               | Duplex-SC   |               |             |
| <b>SRC</b>              |   |               |             |
| SRC lock range          | 41kHz to 216kHz (MADI)  |               |             |
| Sample Rate Ratio Limit | 6:1   |               |             |
| THD                     | -130dB typical  |               |             |
| Latency                 | 43 to 196 samples (Network and MADI sample rate dependent)          |               |             |
| <b>Channel Count</b>    |   |               |             |
| <b>RedNet Clock</b>     |   |               |             |
| <b>MADI Clock</b>       | <b>Single</b>   | <b>Double</b> | <b>Quad</b> |
| Single                  | 64  | 32            | 16          |
| Single Varispeed        | 56  | 32            | 16          |
| Double                  | 32  | 32            | 16          |
| Double Varispeed        | 28  | 28            | 16          |
| Quad                    | 16  | 16            | 16          |
| Quad Varispeed          | 14  | 14            | 14          |
| <b>Power</b>            |   |               |             |
| PSU                     | Internal, Universal type, consumption 30VA                          |               |             |



# REDNET D16

## UNIT CONNECTIONS AND FEATURES

### RedNet 6 - Front Panel

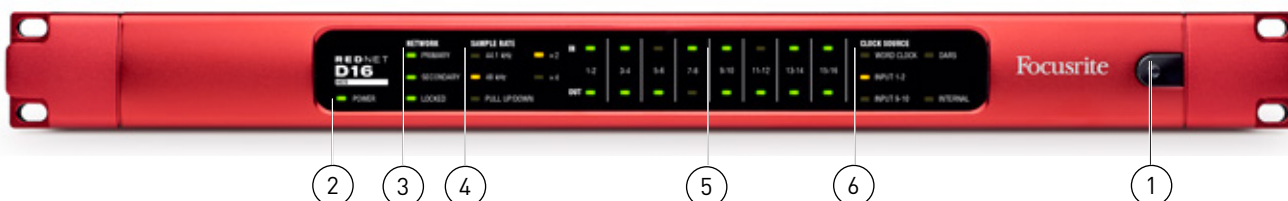

1. **AC Power Switch**
2. **Power Indicator**
3. **RedNet Network Status Indicators:**
  - **PRIMARY** – illuminates when the device is connected to an active Ethernet network.
  - **SECONDARY** – illuminates when the device is connected to an active Ethernet network. Not used when operating in Switched mode.
  - **LOCKED** – illuminates when a valid sync signal is received from the network or the RedNet D16 unit is network master. When an incoming clock signal is invalid, the Locked indicator will flash to indicate that the unit has reverted to using its internal clock.
4. **RedNet Sample Rate Indicators**

Five orange indicators: **44.1 kHz**, **48 kHz**, **x2** (multiple of 44.1 or 48), **x4** (multiple of 44.1 or 48) and sample rate **PULL UP/DOWN**. These Indicators illuminate individually or in combination to indicate the sample rate being used. For example, for a 96kHz pull up/down setting, the 48kHz, x2 and Pull Up/Down indicators will illuminate.
5. **Signal Presence LEDs**

Indicate that an input or an output signal is present for each odd/even channel pair. Illuminate at -126dBFS.
6. **Clock source**

Five orange indicators: **Word Clock**, **Input 1-2**, **Input 9-10**, **DARS** and **Internal**. Whichever is lit identifies the clock reference being used. (When the unit is not a network master, no LEDs will illuminate.)

## RedNetD16 - Rear Panel



### 1. IEC Mains Inlet

Standard IEC receptacle for connection of AC mains. RedNet D16 features a 'Universal' PSU, enabling it to operate on any supply voltage of between 100 V and 240 V.

\* Note: that initial use requires fitment of the plug retaining clip – see page 51.

### 2. Primary Network Port

Dante network connection. Use standard CAT 5e or CAT 6 computer network cables to connect to a local Ethernet switch to connect the RedNet D16 to the RedNet network. Each socket includes integral LEDs which illuminate to indicate a valid network connection plus network activity. See page 54 for connector details.

### 3. Secondary Network Port

Backup Dante network connection where two independent Ethernet links are being used (Redundant mode) or an additional port on an integral network switch on the primary network (Switched mode).

### 4. Word Clock Out

Provides an output of the chosen system clock reference (can be switched between base rate or network rate).

### 5. Word Clock In

Allows synchronisation of the Dante network to house word clock.

### 6. S/PDIF:

- **OUT** – Provides any adjacent odd-even signal pair, eg. 3–4 or 11–12. Software selectable.
- **IN** – Can be used as an alternative input for audio channels 3–4. Software switchable.

### 7. XLR Out

Permanent AES3 output of audio channel pair 1–2.

### 8. XLR In

Can be used as an alternate AES3 audio source for channels 1–2. Software switchable. May also be used as a clock source when fed with either AES3 or DARS (Digital Audio Reference Signal – AES3 distributed clock as per AES11). Software selectable.

### 9. DB25 Connectors

Eight AES/EBU input and output channels per connector. Wired to AES59 Combined Digital I/O. See page 54 for connector pinouts.

## POWER CONNECTION

### IEC Power Cord Retaining Clip

RedNet D16 is supplied with an IEC power cord retaining clip. This prevents accidental disconnection of the power cord during use. When the unit is first installed, the retaining clip will need to be attached to power input socket on the rear panel.

Insert the clip by squeezing together the legs as shown in the first image below, aligning the pins with the through-holes on the IEC fixing posts one at a time, and then releasing.

Ensure that the orientation of the clip is as shown in the other images below or its effectiveness will be compromised.

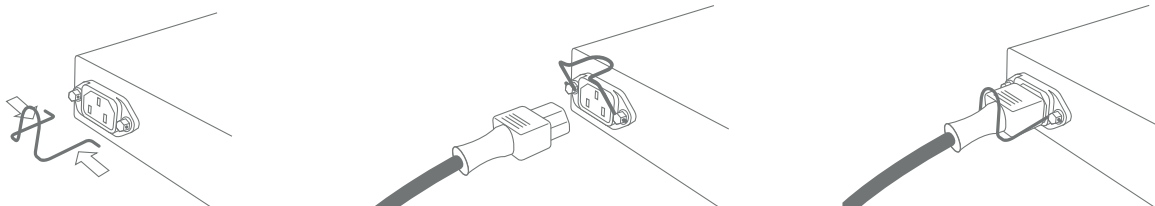

## PHYSICAL CHARACTERISTICS

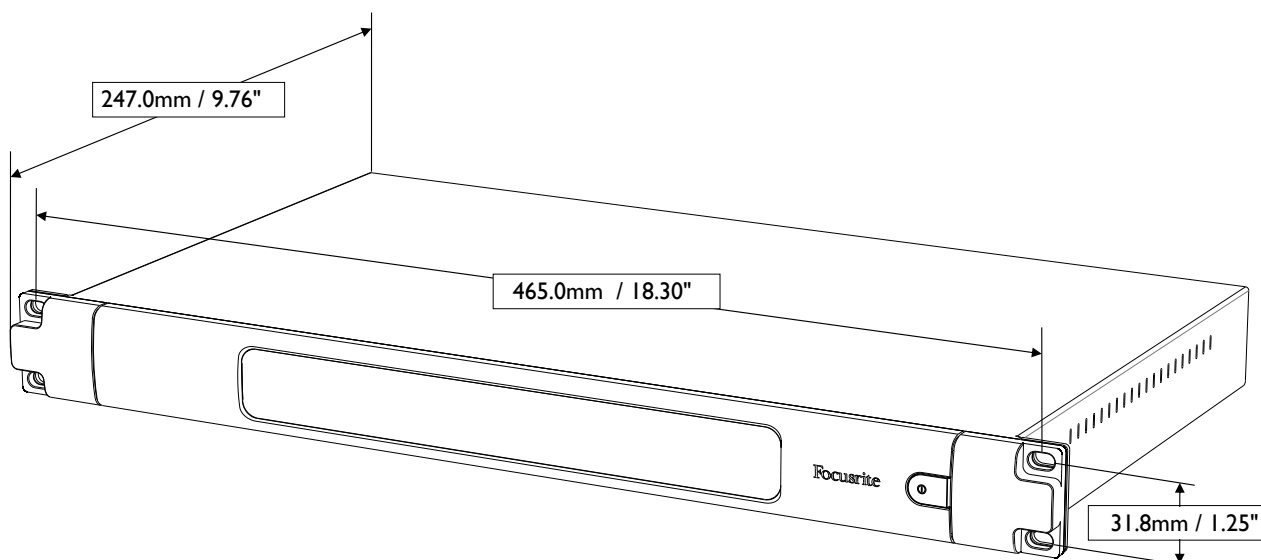

RedNet D16 dimensions are illustrated in the diagram above.

RedNet D16 requires 1U of vertical rack space and at least 350 mm of rack depth, to allow for cables. RedNet D16 weighs 3.74 kg and for installations in a fixed environment (eg., a studio), the front-panel mounting screws will provide adequate support. If the units are to be used in a mobile situation (eg., flight-cased for touring, etc.), consideration should be given to using side support rails within the rack.

RedNet D16 generates little significant heat and is cooled by natural convection.

Ventilation is via slots in the enclosure at both sides. Do not mount RedNet D16 immediately above any other equipment which generates significant heat, for example, a power amplifier. Also, ensure that when mounted in a rack, the side vents are not obstructed.

## POWER REQUIREMENTS

RedNet D16 is mains-powered. It incorporates a 'Universal' power supply, which can operate on any AC mains voltage from 100 V to 240 V. The AC connection is made via a standard 3-pin IEC connector on the rear panel.

A mating IEC cable is supplied with the unit, which should be terminated with a mains plug of the correct type for your country.

The AC power consumption of the RedNet D16 is 30VA.

Please note that there are no fuses in RedNet D16, or other user-replaceable components of any type. Please refer all servicing issues to the Customer Support Team.

# REDNET D16 OPERATION

## FIRST USE AND FIRMWARE UPDATES

Your RedNet D16 will require a firmware update when it is first installed and switched on. Firmware updates are initiated and handled automatically by the RedNet Control application. It is important that the firmware update procedure is not interrupted, either by switching off the RedNet D16 or the computer on which RedNet Control is running or disconnecting either from the network.

From time to time Focusrite will release RedNet firmware updates within new versions of RedNet Control. We recommend keeping all RedNet units up to date with the latest firmware version supplied with each new version of RedNet Control.

## PULL UP AND PULL DOWN OPERATION

RedNet devices are able to run with pull up or pull down sample rates in one of two ways:

- Locking to an external clock at the desired clock frequency
- Operating at a specified pull up or pull down percentage as selected in the Dante Controller application\*

\* Note: Not all RedNet devices currently support this mode of operation.

## SAMPLE RATE CONVERTERS

SRC will need to be switched in for any sources that are not using the current system clock as a reference signal.

SRC can be switched in or out separately for each input channel pair.

\* Note: SRC increases latency slightly.

# CONNECTORS

## Ethernet Connector

Connector type: RJ-45 receptacle  
 Applies to: Ethernet (Dante)

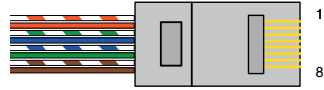

| Pin | Cat 6 Core     |
|-----|----------------|
| 1   | White + Orange |
| 2   | Orange         |
| 3   | White + Green  |
| 4   | Blue           |
| 5   | White + Blue   |
| 6   | Green          |
| 7   | White + Brown  |
| 8   | Brown          |

## DB-25 (AES59) Connector

Connector type: DB-25 receptacle  
 Applies to: AES3 I/O

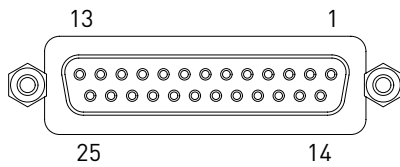

| Pin | Signal             |
|-----|--------------------|
| 1   | Out channels 7/8 + |
| 14  | Out channels 7/8 - |
| 2   | Ground             |
| 15  | Out channels 5/6 + |
| 3   | Out channels 5/6 - |
| 16  | Ground             |
| 4   | Out channels 3/4 + |
| 17  | Out channels 3/4 - |
| 5   | Ground             |
| 18  | Out channels 1/2 + |
| 6   | Out channels 1/2 - |
| 19  | Ground             |
| 7   | In channels 7/8 +  |
| 20  | In channels 7/8 -  |
| 8   | Ground             |
| 21  | In channels 5/6 +  |
| 9   | In channels 5/6 -  |
| 22  | Ground             |
| 10  | In channels 3/4 +  |
| 23  | In channels 3/4 -  |
| 11  | Ground             |
| 24  | In channels 1/2 +  |
| 12  | In channels 1/2 -  |
| 25  | Ground             |
| 13  | n/c                |

## XLR Connectors

Connector type: XLR-3 receptacle  
 Applies to: AES3/DARS Input  
 Connector type: XLR-3 plug  
 Applies to: AES3 Output

| Pin | Signal     |
|-----|------------|
| 1   | Screen     |
| 2   | Hot (+ve)  |
| 3   | Cold (-ve) |

## PERFORMANCE AND SPECIFICATIONS

| Audio Inputs       |   |
|--------------------|---|
| AES/EBU            | 16 channels, with switchable SRC by input pair                                  |
| AES/EBU Connectors | 1–16: 2x 25-way female D-Sub, each wired to AES59 (combined I/O)/Tascam Digital |
|                    | Channels 1–2 (switchable): XLR3F  |
| S/PDIF Input       | Channels 3–4 (switchable)   |
| S/PDIF connector   | RCA Phono socket  |
| Input format       | Channel status ignored. Assumed to be 24 bit, 2-channel audio                   |

| Input Sample Rate Converters |   |
|------------------------------|---|
| Input sample rate range      | 32 to 216 kHz   |
| Gain error                   | -0.3 dB   |
| Dynamic Range                | > 138 dB (-60 dBFS method)                                    |
| THD+N                        | < -130 dB (0.00003%); 0 dBFS input                            |
| Input format                 | Channel status ignored. Assumed to be 24 bit, 2-channel audio |
| Latency                      | 11 to 45 samples (network and input sample rate dependent)    |

| Audio Outputs      |  |
|--------------------|--|
| AES/EBU            | 16 channels, synchronous with unit sample rate   |
| AES/EBU Connectors | Channels 1–16: 2x 25-way female D-Sub, each wired to AES59 (combined I/O) (See "Inputs")                       |
|                    | Channels 1–2: XLR3M  |
| S/PDIF Output      | 2 channels, synchronous with unit sample rate Output can duplicate any adjacent odd/even pair of channels 1–16 |
| S/PDIF connector   | RCA Phono socket   |
| Output format      | AES3   |

| Digital Performance       |   |
|---------------------------|---|
| Supported sample rates    | 44.1 / 48 / 88.2 / 96 / 176.4 / 192 kHz [-4% / -0.1% / +0.1% / +4.167%] at 24 bit |
| Clock Sources             | Internal or from network master device  |
| External word clock range | Nominal sample rate $\pm 7.5\%$   |

| <b>Indicators</b>       |  |
|-------------------------|--|
| Power Indicator         | Green LED  |
| Primary network         | Green LED. Indicates that a network connection is present on primary port when in redundant mode. When in Switched mode, a valid network connection at either Primary or Secondary network port will cause this LED to illuminate. |
| Secondary network       | Green LED. Indicates that a network connection is present on secondary port when in redundant mode. Not used in switched mode.   |
| Locked                  | Green LED. When unit is network slave, shows valid network lock, when network master shows unit is locked to indicated clock source. Flashing means invalid external clock present and unit has reverted to internal clock.        |
| Unit sample rate        | Orange LED for each: 44.1 kHz, 48 kHz, x2, x4  |
| Pull/up down            | Indicates unit is set to operate on a Dante pull up/down domain  |
| Signal indicators       | 16 Green LEDs, 8 input/8 output indicators. Illuminate at -126 dBFS  |
| Clock source indicators | Orange LED for each: Internal, Word Clock, DARS, Input 1-2, Input 9-10   |

| <b>Network Modes</b> |  |
|----------------------|--|
| Redundant            | Allows unit to connect to two independent networks                                 |
| Switched             | Connects both ports to integrated network switch allowing daisy-chaining of device |

| <b>Power</b> |                                       |
|--------------|---------------------------------------|
| PSU          | Internal, 100-240V, consumption 30 VA |



# REDNET PCIe

## UNIT CONNECTIONS AND FEATURES

### RedNet I/O interfaces

Full details of the front panel controls, indicators and rear panel connections of the various RedNet hardware interfaces will be found in earlier in this installation guide.

### Rednet PCIe card

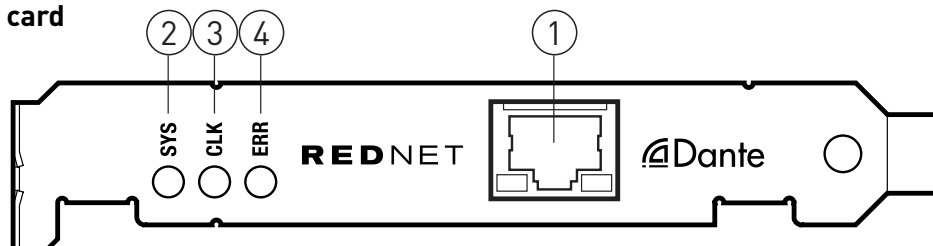

1. RJ45 network socket. Connect this to the Gigabit network switch local to the computer. The port is the primary interface for all the channels of audio on the RedNet network. The socket has integral LEDs which illuminate to indicate connection to an active network port, and network activity. Please note RedNet PCIe is not a standard network card. If the computer which RedNet PCIe is installed in is required to run Dante Controller or RedNet Control, a second Ethernet cable will need to be connected between the computer's onboard Ethernet port and the Ethernet switch.
2. **SYS** – multi-colour LED indicating the card's Dante system status:
  - Green – normal operation
  - Orange – system failure
3. **CLK** – multi-colour LED indicating the card's sync status:
  - Green (steady) – confirms card is a Dante PTP slave; the card will sync to the clock embedded in the incoming Dante bitstream
  - Green (blinking) – confirms card is a Dante PTP master; the card is set (in Dante Controller) to generate the Dante clock which will be used by other units.
  - Orange – sync failure
4. **ERR** – reserved for future use.

**NOTE:** additional LED displays are thus:

- All LEDs red – card has entered failsafe mode. If this situation occurs, users are recommended to contact Focusrite Customer Support.
- All LEDs blinking green – identify function has been activated from Dante Controller.

The RedNet PCIe card is a standard single-width PCIe card which will fit an empty card slot in a PC or Mac. The slot used must be "4-lane" minimum, though 16-lane is necessary to achieve maximum performance. Please check your computer's motherboard documentation if you are unsure of the slot specification.

The RedNet PCIe card is powered by the computer in which it is installed. It conforms to the PCIe card supply voltage standard, and provided your computer's PSU is working normally, you should experience no power-related issues with any computer.

## INSTALLING THE REDNET PCIe CARD

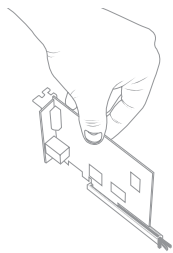

The computer should be disconnected from the AC mains supply before attempting to install the PCIe card. Allow the computer to cool before starting the installation.



Anti-static precautions should be taken when handling the card once it is removed from its anti-static bag; only handle the card by gripping the card by its edges and avoid touching any of the component parts.

Place the computer on a clean, flat surface. Open the computer as necessary, to access the PCIe card slots. Install the RedNet PCIe card carefully, ensuring that it is firmly and securely in place. Close the computer and re-connect its power supply.

# INSTALLING REDNET CONTROL

All software required for a RedNet system is available for download from the Focusrite website [www.focusrite.com/register](http://www.focusrite.com/register). The Software Activation card provided with your RedNet unit contains validation codes which you will need to enter in the Downloads area. This procedure ensures that you will have the most up-to-date software versions.

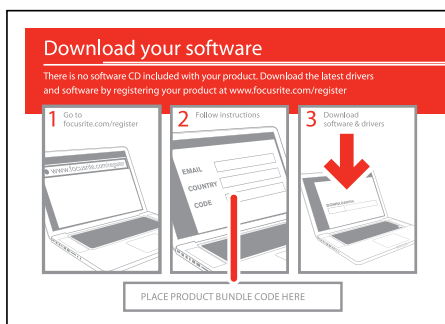

Go to [www.focusrite.com/register](http://www.focusrite.com/register), and follow the instructions on the software card to register your product and download RedNet Control and associated software.

When all downloads are complete, install the RedNet drivers and RedNet Control application in the usual manner. Follow all on-screen instructions from this point.

## AUDINATE DANTE CONTROLLER

This software application is automatically installed when the RedNet Control is installed. Dante Controller is a useful addition to, but not essential for, simpler systems. Most RedNet functions can be controlled from RedNet Control, but non-standard routings can be defined in Dante Controller.

Dante Controller can also be downloaded from [www.audinate.com](http://www.audinate.com). Register first, then download and install.

## CONNECTING YOUR REDNET AUDIO NETWORK

Remove any Ethernet cables connected to your computer (these can be reconnected after setting up RedNet - either to the Gbit switch, or to any additional vacant Ethernet ports you have on your computer).

Connect a vacant Ethernet port on your computer to a port on your Gbit Switch with a Cat6 Ethernet cable. If you have installed a RedNet PCIe card, connect its Ethernet port to a port on the Gbit switch with a second Cat6 Ethernet cable.

Connect the Ethernet ports on the rear of each RedNet I/O interface in the system to further ports on the Gbit switch with Cat6 Ethernet cables.

The recommended order of powering the components in a RedNet system is as follows:

- Power up the Gbit switch;
- Power up all RedNet units on the networks one by one (power-on sequence takes approx. 40 s per unit)
- Boot the host computer.

# NETWORK REQUIREMENTS

## ETHERNET CABLING REQUIREMENTS

A RedNet network requires a Gigabit network infrastructure. The following cable types are permitted:

- CAT 5e
- CAT 6

Both shielded and unshielded cables are suitable. Though if available, Cat 6 STP should be deployed.

As dictated by the ANSI/TIA/EIA standards for network cabling, the maximum combined cable length between devices is 100m. This allows an installed cable to be up to 90m long, leaving a length of 5m of shorter cable to connect to the devices at each end.

Typically, this connection would be between one RedNet unit and a switch, or one switch and another switch.

Please note that neither Wireless Networking nor Wide Area Networks are supported with RedNet.

## NETWORK SWITCHES

Networked audio with RedNet is simple. For the majority of systems, setup will be extremely straightforward. The following guide details exactly what to do with your switch when setting up the network. Whether you're new to networking or a seasoned IT professional, the information below will be easy to implement.

### What to look for in a switch

The RedNet Dante network requires the use of at least one Gigabit Ethernet switch. In larger installations multiple switches will be needed. While some networks may function with unmanaged switches, performance varies widely with available switches. It is therefore required that a managed gigabit Ethernet switch is used with any RedNet system in order to guarantee rock-solid audio performance.

Here are the requirements of any switch to be used with a RedNet system:

- Gigabit rated (1000 Mbps)
- Non-blocking
- Quality of Service (QoS) with four queues
- Diffserv (DSCP) QoS with strict priority
- Switches with a built-in power supply are recommended for optimum audio performance

### Specific switch examples

Unlike other networked audio systems, Dante (and therefore RedNet) works with standard, off-the-shelf Ethernet hardware, which is commonly available and needn't be expensive. There are many switches available with varying features, number of ports and in various sizes. Although not an exhaustive list, below are some switches that Focusrite has found to be ideal for RedNet:

- Cisco SG200-18
- Cisco SG200-26
- Cisco SG300-10
- Netgear GS724T
- Netgear GS716T

### How to set up your switch

To set up the managed switch, the following DSCP values should be given the priority shown in the table. Please refer to the user guide of your managed switch for instructions on how to set DSCP packet priority values. This may be under a section called QoS or Quality of Service.

| DSCP Value | Priority | Usage                    |
|------------|----------|--------------------------|
| CS7        | High     | Time critical PTP events |
| EF         | Medium   | Audio, PTP               |
| CS1        | Low      | (reserved)               |
| BestEffort | None     | Other traffic            |

Where the switch offers it, Trust Ingress DSCP Values must be enabled. For systems with any multicast data, IGMP Snooping should be switched on.

In addition to these QoS settings it is important that Green Ethernet, or EEE, is switched off as it can cause audio dropouts. For an example of how to set up the Cisco SG200 series switches, please visit [www.focusrite.com/rednet](http://www.focusrite.com/rednet)

### FIBRE OPTIC NETWORKS

Using a fibre network can greatly increase the distance across which your audio can be transmitted and received. RedNet devices cannot themselves connect directly to an optical network, however many gigabit Ethernet switches provide the provision for optical modules, allowing you to have a fibre optic infrastructure with the nodes (in this case RedNet devices) connected to the network with Cat 5e or Cat 6 cable to a local switch.

For details on how to set up a fibre optic network please refer to the documentation supplied with your gigabit Ethernet switch.

# CONNECTION DIAGRAMS AND EXAMPLE SETUPS

**DIAGRAM 1**

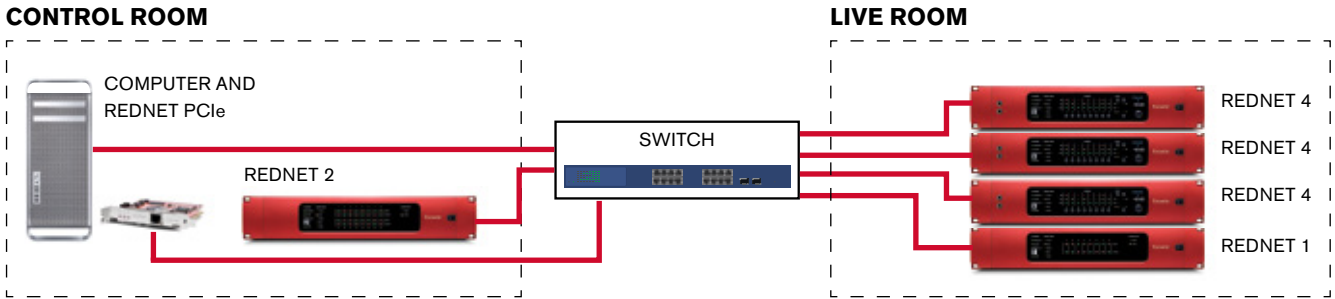

## Recording Studio with RedNet PCIe host

This setup provides low latency recording for a typical two-room studio. Here, control room monitoring and line inputs are catered for by RedNet 2. In the live room, three RedNet 4 units provide 24 channels of remote control mic pres and RedNet 1 provides line level monitoring sends

**DIAGRAM 2**

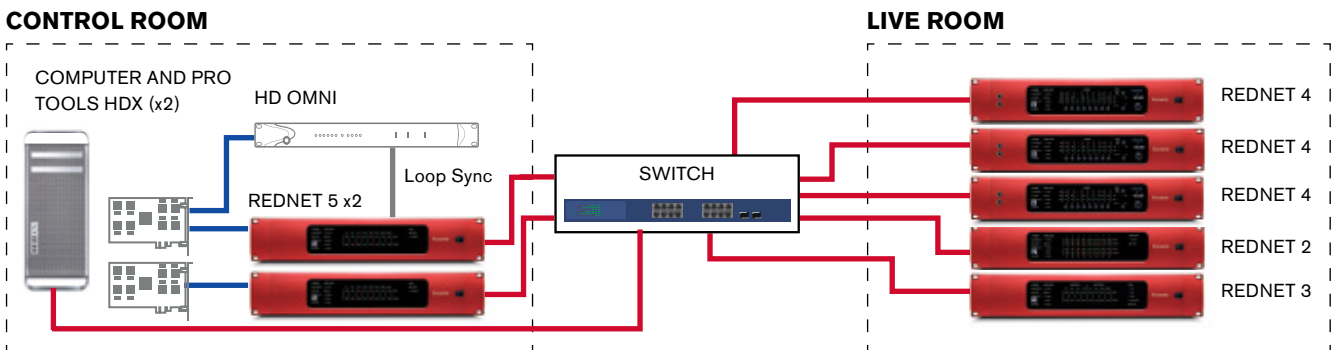

## Pro Tools HD with RedNet

RedNet 5 allows any Pro Tools HD system to integrate seamlessly with the Dante network. Here, the Avid OMNI is used for control room monitoring and local input signals. It is connected to one of two RedNet 5 units via Loop Sync. Note that the second RedNet 5 does not require a Loop Sync connection as it receives its clocking signal over the network. The two RedNet 5 units provide up to 64 channels I/O to/from the Pro Tools HD system and RedNet. Any number of RedNet interfaces could be connected to the switch. In this scenario, three RedNet 4 units are providing 24 channels of remote controlled mic preamps, a RedNet 2 unit provides 16 channels of line level I/O, and RedNet 3 allows the connection of up to 32 channels I/O of ADAT signals, even at 96 kHz.

| CABLE KEY                             |                 |
|---------------------------------------|-----------------|
| <span style="color: red;">█</span>    | CAT 5e or CAT 6 |
| <span style="color: blue;">█</span>   | DigiLink        |
| <span style="color: orange;">█</span> | Fiber           |

**DIAGRAM 3**

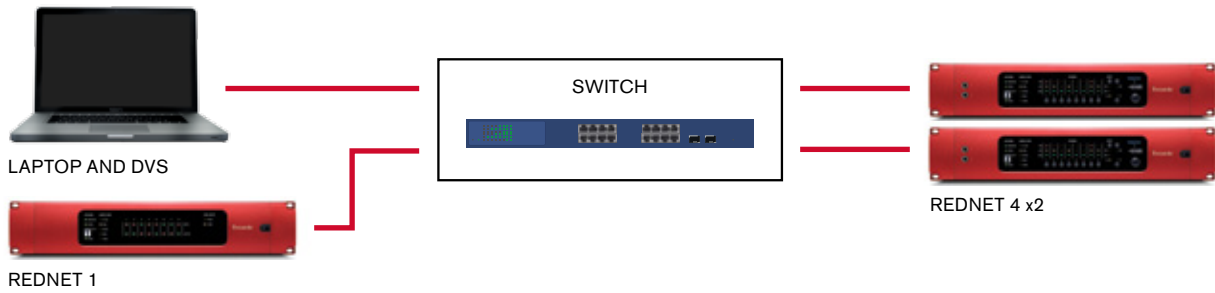

**Basic Location Recording Setup using DVS (without PCIe card)**

Dante Virtual Soundcard provides a great solution for the mobile recording engineer. Simply plug into your onboard Ethernet port with a CAT 6 cable, and connect to RedNet interfaces via a switch. Here, two RedNet 4 units provide 16 channels of remote controlled mic pres (which could be placed under/near the stage) and a single RedNet 1 unit provides the line I/O for monitoring the recording. Remember that as RedNet uses standard Ethernet hardware, each CAT 6 cable can be up to 100m (109 yards) in length, perfect for location recording. See p.51 for more details.

**DIAGRAM 4**

**AUDITORIUM**

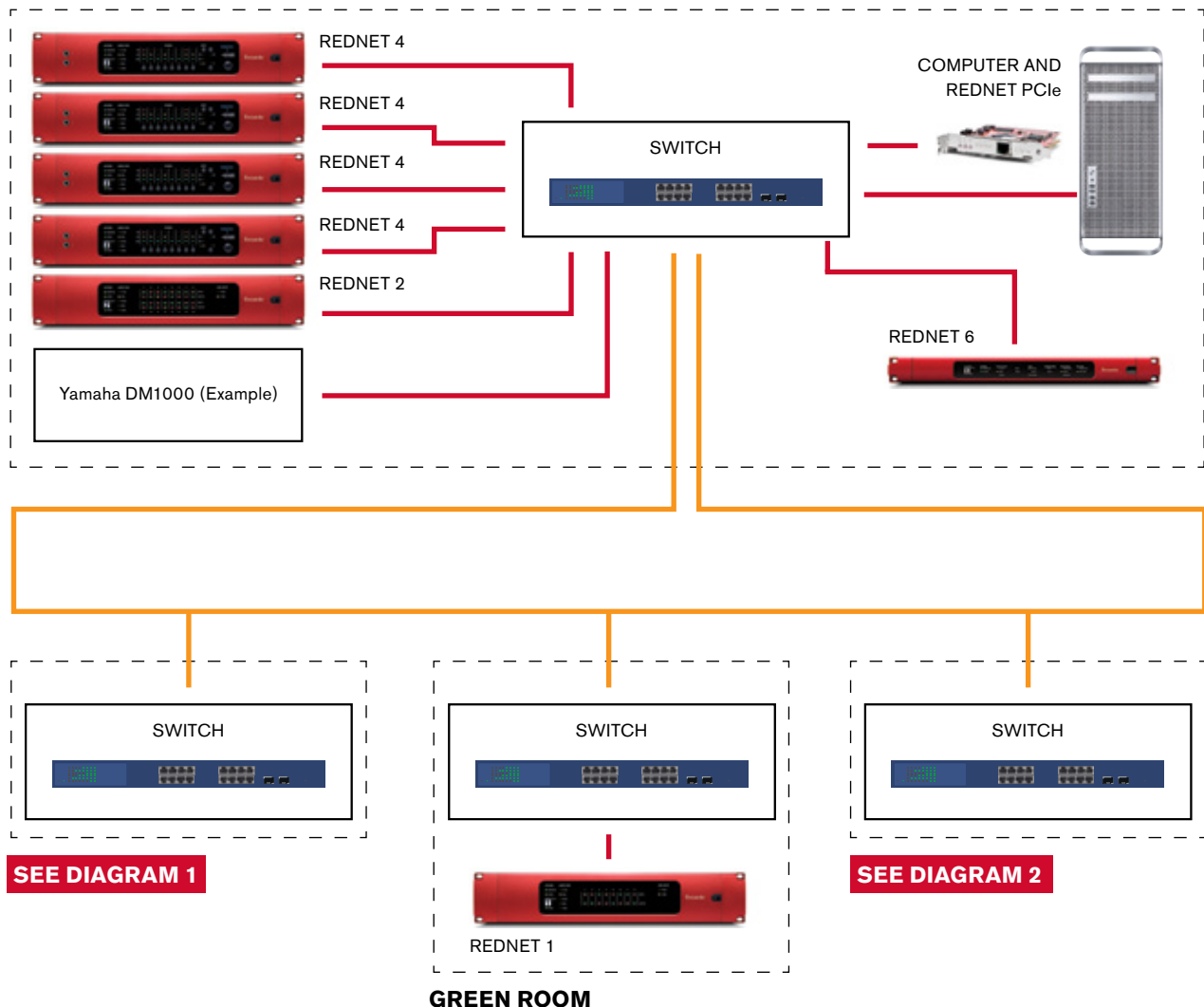

## FOCUSRITE REDNET WARRANTY AND SERVICE

All Focusrite products are built to the highest standards and should provide reliable performance for many years, subject to reasonable care, use, transportation and storage.

Very many of the products returned under warranty are found not to exhibit any fault at all. To avoid unnecessary inconvenience to you in terms of returning the product please contact Focusrite support.

In the event of a Manufacturing Defect becoming evident in a product within 12 months from the date of the original purchase Focusrite will ensure that the product is repaired or replaced free of charge.

A Manufacturing Defect is defined as a defect in the performance of the product as described and published by Focusrite. A Manufacturing Defect does not include damage caused by post-purchase transportation, storage or careless handling, nor damage caused by misuse.

Whilst this warranty is provided by Focusrite the warranty obligations are fulfilled by the distributor responsible for the country in which you purchased the product.

In the event that you need to contact the distributor regarding a warranty issue, or an out-of-warranty chargeable repair, please visit: [www.focusrite.com/distributors](http://www.focusrite.com/distributors)

The distributor will then advise you of the appropriate procedure for resolving the warranty issue. In every case it will be necessary to provide a copy of the original invoice or store receipt to the distributor. In the event that you are unable to provide proof of purchase directly then you should contact the reseller from whom you purchased the product and attempt to obtain proof of purchase from them.

Please do note that if you purchase a Focusrite product outside your country of residence or business you will not be entitled to ask your local Focusrite distributor to honour this limited warranty, although you may request an out-of-warranty chargeable repair.

This limited warranty is offered solely to products purchased from an Authorised Focusrite Reseller (defined as a reseller which has purchased the product directly from Focusrite Audio Engineering Limited in the UK, or one of its Authorised Distributors outside the UK). This Warranty is in addition to your statutory rights in the country of purchase.

## REGISTERING YOUR PRODUCT

For technical support, please register your product at: [www.focusrite.com/register](http://www.focusrite.com/register)

## CUSTOMER SUPPORT AND UNIT SERVICING

You can contact Focusrite Customer Support at:

Email: [supportteam@focusrite.com](mailto:supportteam@focusrite.com)

Phone (UK): +44 (0)1494 462246

Phone (USA): +1 (310) 322-5500

## TROUBLESHOOTING

If you are experiencing problems with your RedNet 1, we recommend that in the first instance, you visit our Support Answerbase at: [www.focusrite.com/answerbase](http://www.focusrite.com/answerbase)



# IMPORTANT SAFETY INSTRUCTIONS

1. Read these instructions.
2. Keep these instructions.
3. Heed all warnings.
4. Follow all instructions.
5. Do not use this apparatus near water.
6. Clean only with dry cloth.
7. Do not block any ventilation openings. Install in accordance with the manufacturer's instructions.
8. Do not install near any heat sources such as radiators, heat registers, stoves, or other apparatus (including amplifiers) that produce heat.
9. Do not defeat the safety purpose of the polarized or grounding-type plug. A polarized plug has two blades with one wider than the other. A grounding type plug has two blades and a third grounding prong. The wide blade or the third prong are provided for your safety. If the provided plug does not fit into your outlet, consult an electrician for replacement of the obsolete outlet.
10. Protect the power cord from being walked on or pinched particularly at plugs, convenience receptacles, and the point where they exit from the apparatus.
11. Only use attachments/accessories specified by the manufacturer.
12.  Use only with the cart, stand, tripod, bracket, or table specified by the manufacturer, or sold with the apparatus. When a cart is used, use caution when moving the cart/apparatus combination to avoid injury from tip-over.
13. Unplug this apparatus during lightning storms or when unused for long periods of time.
14. Refer all servicing to qualified service personnel. Servicing is required when the apparatus has been damaged in any way, such as power-supply cord or plug is damaged, liquid has been spilled or objects have fallen into the apparatus, the apparatus has been exposed to rain or moisture, does not operate normally, or has been dropped.
15. No naked flames, such as lighted candles, should be placed on the apparatus.

The appliance coupler is used as the disconnect device, the disconnect device shall remain readily operable.

Do not use a damaged or frayed power cord.

If the mains plug supplying the apparatus incorporates a fuse then it should only be replaced with a fuse of identical or lower rupture value.

**GB** The apparatus shall be connected to a mains socket outlet with a protective earthing connection.

**FIN** Laite on liitettävä suojamaadoituskoskettimilla va rustettuumpistorasiaan

**NOR** Apparatet må tikoples jordet stikkontakt

**SWE** Apparaten skall anslutas till jordat uttag



**CAUTION:** TO REDUCE THE RISK OF ELECTRIC SHOCK, DO NOT REMOVE COVER (OR BACK). NO USER-SERVICEABLE PARTS INSIDE. REFER SERVICING TO QUALIFIED SERVICE PERSONNEL.



The lightning flash with arrowhead symbol, within equilateral triangle, is intended to alert the user to the presence of uninsulated "dangerous voltage" within the product's enclosure that may be of sufficient magnitude to constitute a risk of electric shock to persons.



The exclamation point within an equilateral triangle is intended to alert the user to the presence of important operating and maintenance (servicing) instructions in the literature accompanying the appliance.

**WARNING:** TO REDUCE THE RISK OF FIRE OR ELECTRIC SHOCK, DO NOT EXPOSE THIS APPARATUS TO RAIN OR MOISTURE AND OBJECTS FILLED WITH LIQUIDS, SUCH AS VASES, SHOULD NOT BE PLACED ON THIS APPARATUS.

## ENVIRONMENTAL DECLARATION

### Compliance Information Statement: Declaration of Compliance procedure

Product Identification: Focusrite RedNet  
 Responsible party: American Music and Sound  
 Address: 4325 Executive Drive  
 Suite 300  
 Southaven  
 MS 38672  
 Telephone: 800-431-2609

This device complies with part 15 of the FCC Rules. Operation is subject to the following two conditions: (1) This device may not cause harmful interference, and (2) this device must accept any interference received, including interference that may cause undesired operation.

### For USA

#### To the User:

- 1. Do not modify this unit!** This product, when installed as indicated in the instructions contained in this manual, meets FCC requirements. Modifications not expressly approved by Focusrite may void your authority, granted by the FCC, to use this product.
- 2. Important:** This product satisfies FCC regulations when high quality shielded cables are used to connect with other equipment. Failure to use high quality shielded cables or to follow the installation instructions within this manual may cause magnetic interference with appliances such as radios and televisions and void your FCC authorization to use this product in the USA.
- 3. Note:** This equipment has been tested and found to comply with the limits for a Class A digital device, pursuant to part 15 of the FCC Rules. These limits are designed to provide reasonable protection against harmful interference in a commercial environment. This equipment generates, uses and can radiate radio frequency energy and, if not installed and used in accordance with the instructions, may cause harmful interference to radio communications. Operation of this equipment in a residential area is likely to cause harmful interference in which the user will be required to correct the interference at his own expense

### For Canada

#### To the User:

This Class A digital apparatus complies with Canadian ICES-003.

Cet appareil numérique de la classe A est conforme à la norme NMB-003 du Canada.

#### RoHS Notice

Focusrite Audio Engineering Limited has conformed where applicable, to the European Union's Directive 2002/95/EC on Restrictions of Hazardous Substances (RoHS) as well as the following sections of California law which refer to RoHS, namely sections 25214.10, 25214.10.2, and 58012, Health and Safety Code; Section 42475.2, Public Resources Code.