

TwinPlex  
TwinPlex -- TwinPlex™ Lavalier Microphones  
The Shure TwinPlex Lavalier online user guide.  
Version: 5 (2019-D)

# TwinPlex

## TwinPlex™ Lavalier Microphones

### General Description

# TWIN:PLEX™



The Shure TwinPlex subminiature omnidirectional lavaliers are designed to perform better than other 5 mm lavalier microphones for professional theater, film, tv, and corporate events. The TwinPlex dual-diaphragm technology yields extraordinary gain-before-feedback, off-axis response, and low self-noise while delivering life-like, exceptional clarity free of digital interference. The cable itself is ultra quiet and has been tested to be the longest-lasting, most dependable cable in its class. The TwinPlex series features the most extensive accessories and connector options to date. TwinPlex 5 mm lavs not only meet premium market-leading expectations, they exceed them.

### Features

- Exceptional sound quality from the all new TwinPlex dual-diaphragm element
  - Robust low frequency response with flat top end

- Best in class specifications and dynamic range
- Consistent off axis response results in increased gain before feedback
- Durability beyond the competition
  - Exclusive, double helix cable technology with redundant grounding
  - Nanocoated frequency caps for reduced sweat out
- Comprehensive accessories and microphone offerings
  - Over 60 color, sensitivity, frequency response, and connector options available
  - All new clips, mounts, and accessories designed on extended research and field testing
- High RF immunity for use with today's digital wireless systems.
- Paintable cables allow for discreet placement in professional theater applications.
- Interchangeable frequency response caps offer adjustable flat or presence responses (TL45, TL46, TL47).

## Model Variations

Shure TwinPlex lavaliers are available in a variety of connector and sensitivity levels.

Model	Sound	Sensitivity	Connector	Cable Type
TL45 series	Natural	Low	LEMO	1.1mm (Paintable)
TL46 series	Natural	High	LEMO, MTQG	1.6mm (Paintable)
TL47 series	Natural	Low	LEMO, MDOT, MTQG, XLR, NC	1.6mm (Paintable)
TL48 series	Speech	Low	LEMO, MDOT, MTQG, NC	1.6mm (Paintable)

## Model Variations Key

TL47 T/O-MTQG-A

Series      Color      Polar Pattern      Connector      Accessories

Series	Color	Polar Pattern	Connector	Accessories
TL45	B: Black	O: Omnidirectional	LEMO: LEMO3 bodypacks	A: Accessories included
TL46	C: Cocoa		MTQG: TA4F/TQG Shure bodypacks	
TL47	T: Tan		XLR: includes XLR preamplifier	
TL48	W: White		NC: no connector MDOT: MicroDot (requires adapter)	

**Note:** Not all model variations are available. Refer to [www.shure.com/twinplex](http://www.shure.com/twinplex) for the most up to date offerings.

## The Shure TwinPlex Cartridge

Over 6 years in development, the patent pending, TwinPlex Omnidirectional element was designed to offer best in class sound quality and specifications of any lavalier to date. It utilizes a dual-diaphragm design with two side firing elements as opposed to a single, end fired design. By essentially doubling the surface area of the diaphragm in the same amount of space, the TwinPlex design offers robust low frequency response, exceptional off-axis consistency, increased gain-before-feedback and low handling noise, resulting in a new tier of performance for 5mm microphones.

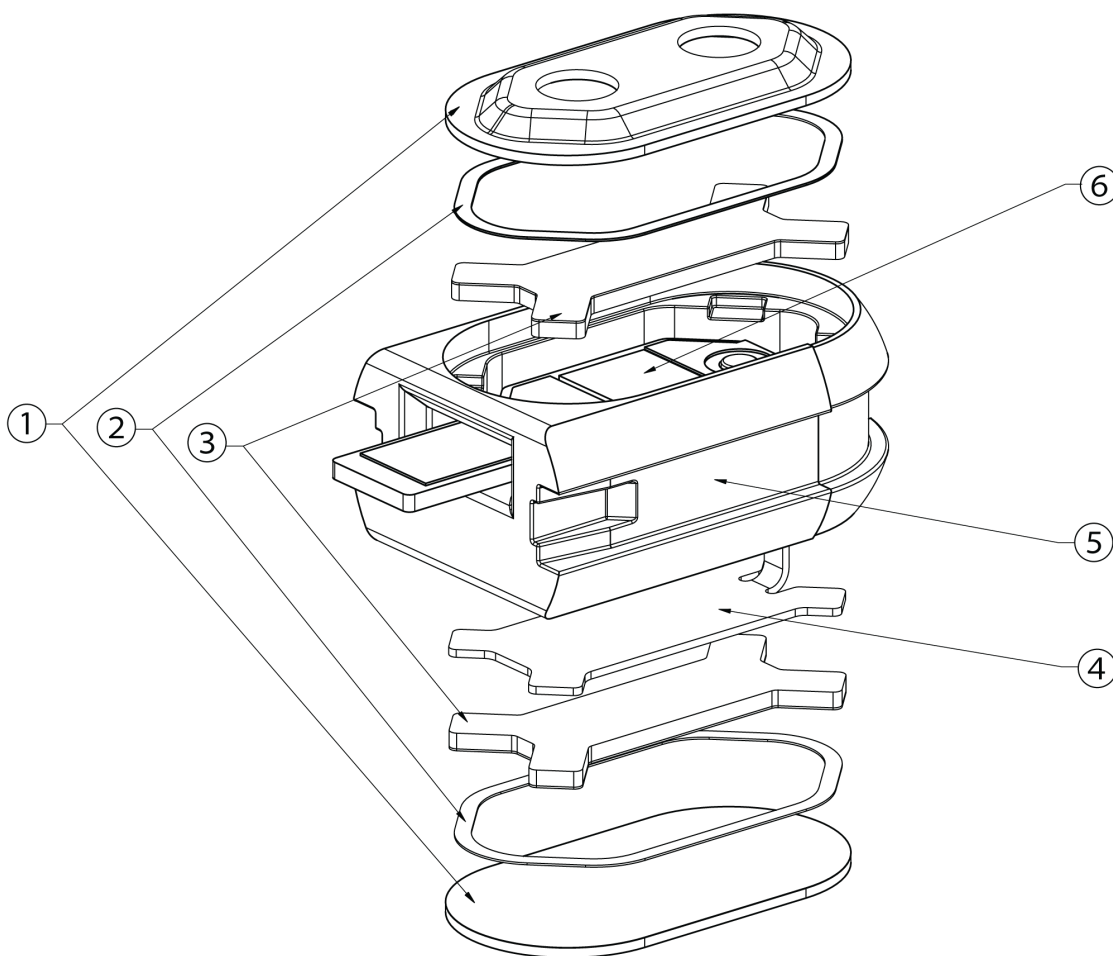

TwinPlex cartridge exploded view

- ① Diaphragm Assembly
- ② Spacer Washer
- ③ Backplate Assembly
- ④ Contact Spacer
- ⑤ Nest

## Care and Maintenance

The TwinPlex lavalier dual-diaphragm has a nanocoating which rejects the build-up of grit from sweat and water. It is designed to withstand being blown out with a can of air for quick clean-up.

## TwinPlex Accessories Quick Start



### Frequency Caps

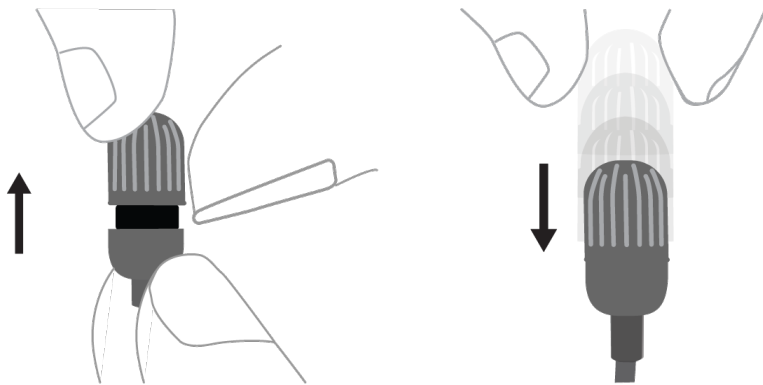

TL45 / TL46 / TL47



TL48

# Attaching the Windscreen

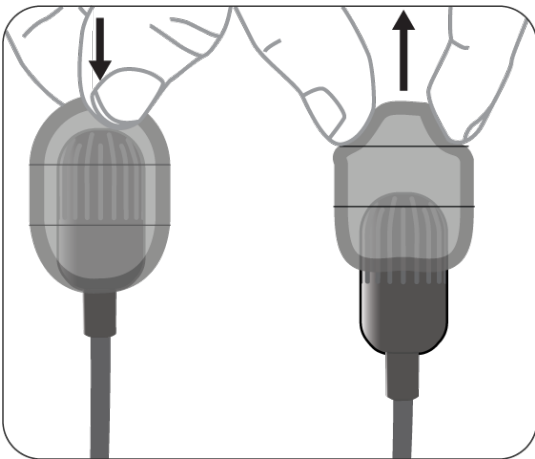

# Lavalier Standoff

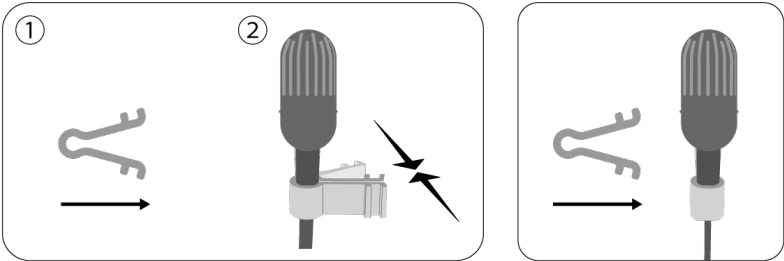

# Tie Clip

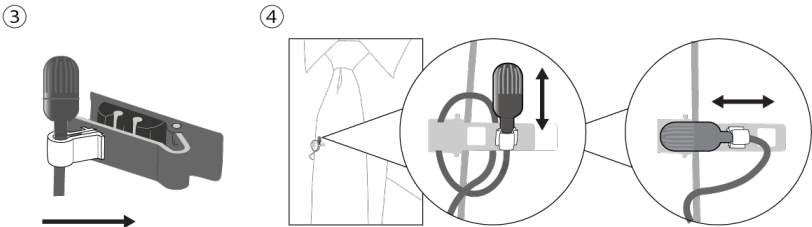

# Dual Tie Clip

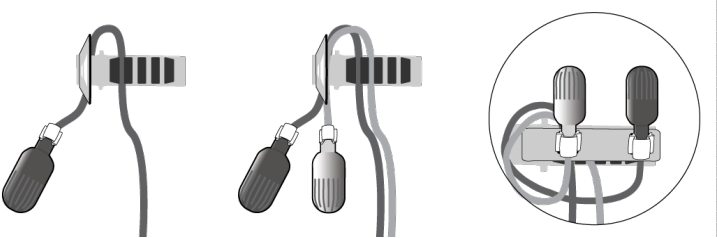

## Vampire Clip

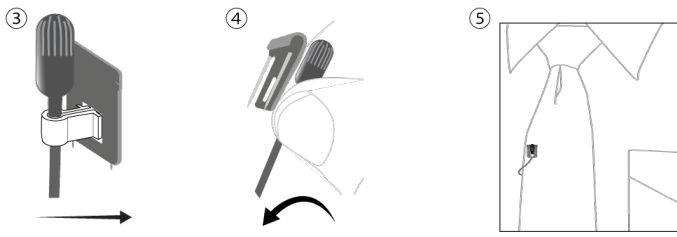

## Sticky Mount

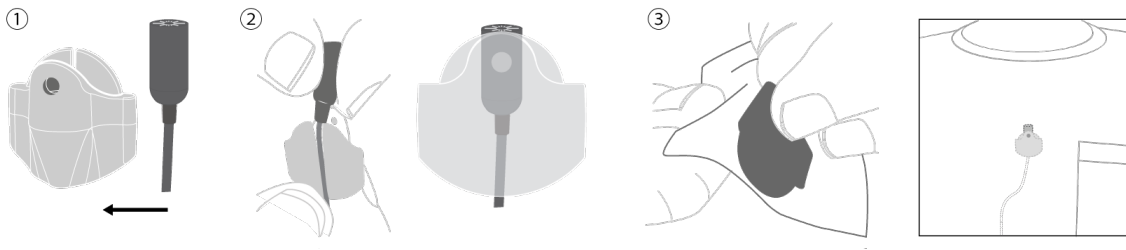

## Sticky Vampire Clip

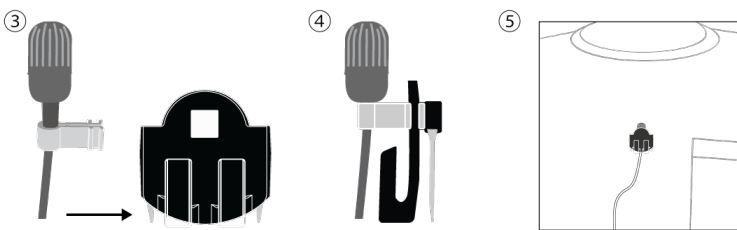

## Lavalier Distance

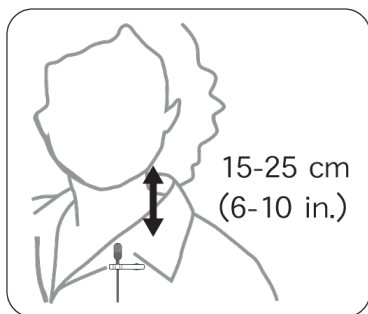

# Threaded Mount Instructions

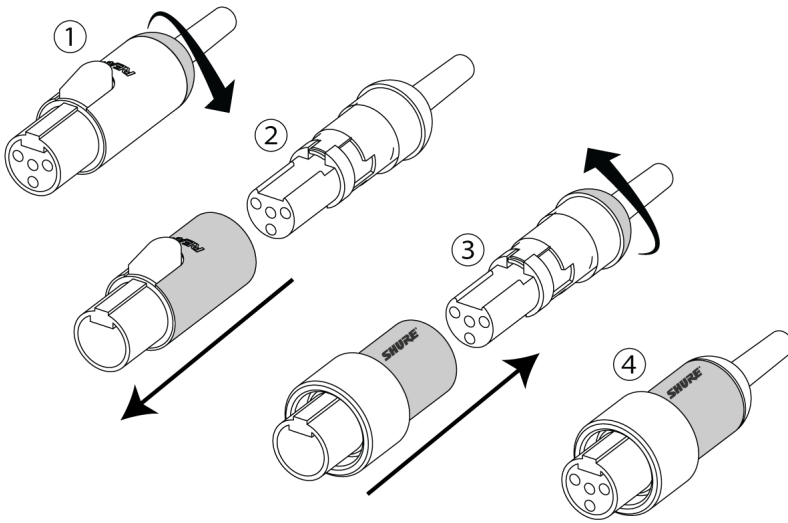

## Specifications

All specification values are based on using a typical bodypack with 5 V bias input or the RPM400MTQG preamplifier. When using the RPM400LEMO amplifier, refer to the RPM400LEMO specifications. <sup>[1]</sup>

### Microphone Capsule

Dual-Diaphragm, Prepolarized Condenser

### Polar Pattern

Omnidirectional

### Frequency Response

20 Hz to 20 kHz

### Sensitivity

TL46	-37.0 dBV(14.1 mV)at 1 kHz <sup>[2]</sup>
TL45, TL47, TL48	-45.0 dBV(5.62 mV)at 1 kHz <sup>[2]</sup>

### Self-Noise, A-Weighted, Equivalent Acoustical

TL46	24.0 dB SPL-A
TL45, TL47, TL48	24.5 dB SPL-A

## Signal-To-Noise Ratio [3]

TL46	70.0 dB
TL45, TL47, TL48	69.5 dB

## Output Clipping Level

3.0 dBV, 1 kHz at 1% THD, typical

## Maximum SPL [4]

TL46	134.0 dB SPL, 1 kHz at 1% THD, typical
TL45, TL47, TL48	142.0 dB SPL, 1 kHz at 1% THD, typical

## Dynamic Range

TL46	110.0 dB typical
TL45, TL47, TL48	117.5 dB typical

## Microphone Current Draw

120 to 240  $\mu$ A, typical

## Bias Voltage

Recommended Operating Voltage

5 V DC

## Housing

Molded ABS

## Polarity

MTQG, XLR connector	Positive pressure on diaphragm produces positive voltage on pin 3 with respect to pin 1
LEMO, NC, MDOT	Positive pressure on diaphragm produces negative voltage on pin 3 with respect to pin 1.

## Cable Diameter

TL45	1.1 mm
TL46, TL47, TL48	1.6 mm



## Cable Length

MTQG, LEMO, MDOT	66 in. (1.67 m)
NC, XLR connector	96 in. (2.43 m)

## Net Weight

with cable

12.0 g(0.42 oz.)

[1]All specifications measured with a 48 Vdc phantom power supply. The microphone operates at lower voltages, but with slightly decreased headroom and sensitivity.

[2] $1 \text{ Pa}=94 \text{ dB SPL}$

[3]S/N ratio is the difference between 94 dB SPL and equivalent SPL of self noise, A-weighted

[4]THD of microphone preamplifier when applied input signal level is equivalent to cartridge output at specified SPL

## Dimensions

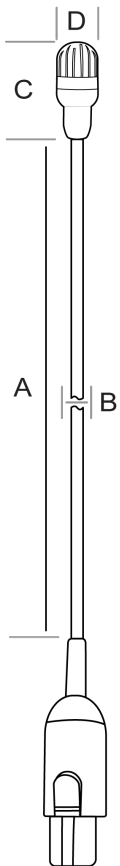

	<b>A</b> Cable Length	<b>B</b> Cable Diameter	<b>C</b> Microphone Length	<b>D</b> Microphone Diameter
<b>TL45</b>	66 in. (1.67M)	1.1MM	13.5MM	5.6MM
<b>TL46</b>	66 in. (1.67M)	1.6MM	13.5MM	5.6MM
<b>TL47-MTQG, TL47-MDOT, TL47-LEMO</b>	66 in. (1.67M)	1.6MM	13.5MM	5.6MM
<b>TL47-XLR, TL47-NC</b>	96 in. (2.43M)	1.6MM	13.5MM	5.6MM
<b>TL48-MTQG, TL48-MDOT, TL48-LEMO</b>	66 in. (1.67M)	1.6MM	19MM	5.3MM
<b>TL48-XLR, TL48-NC</b>	96 in. (2.43M)	1.6MM	19MM	5.3MM

## Frequency Response

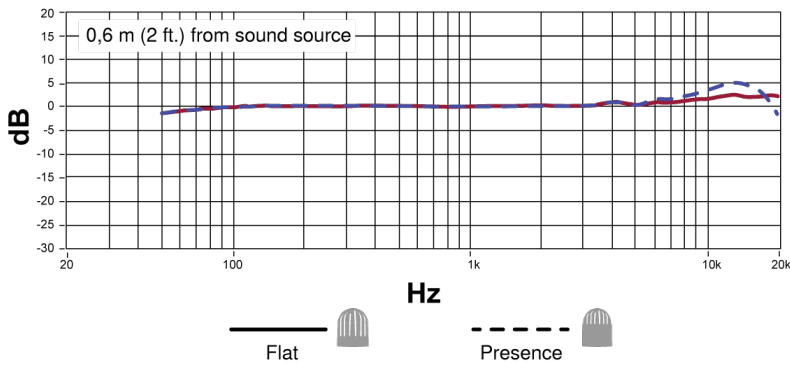

TL45 / TL46 / TL47

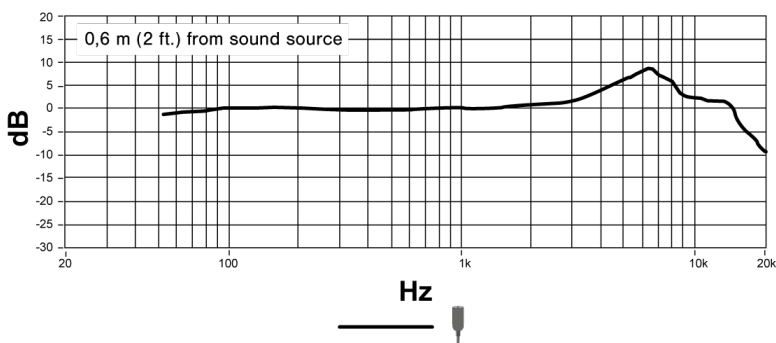

TL48

# Accessories

## Replacement Parts

MTQG/TA4F 4-pin Connector (Shure® Bodypacks)	WA430
Neutrik MTQG 5-pin Connector Kit (Lectrosonics® Bodypacks)	WA435
TL45 Lemo Connector for 1.1mm cables	WA411
TL46/47/48/TH53 Lemo Connector for 1.6mm cables	WA416

### MicroDot adapters for -MDOT versions

MicroDot to LEMO 3 Pin for Shure® and Sennheiser® Bodypacks	MD40LEMO
MicroDot to TA4F/TQG for (Shure® Bodypacks)	MD40TA4F
MicroDot to TA5F/TQG (Lectrosonics® Bodypacks)	MD40TA5F

## Furnished Accessories

### -A Series

Frequency Caps, Flat Response	RPM40FC
Frequency Caps, Presence Response	RPM40PC
Single Tie Clip	RPM40STC
Dual Tie Clip	RPM40TC
Standoff for Clips	RPM40SO
Vampire Mount	RPM40VM
Sticky Vampire Mount	RPM40SVM
Foam Windscreen	RPM40WS
Clear Sticky Mount	RPM40SM
Sticky Mount Adhesives (15 Pieces)	RPM40TS
Sticky Mount Adhesives (50 Pieces)	RPM40TS/50
Neutrik Threaded Shell for WA430/WA435	WA445
Storage Case	RPM40CASE

Accessories are available in Black (/B), Tan (/T), Cocoa (/C), White (/W), and Mixed (/M) color varieties. Please consult your Shure representative for available options.

### -XLR Series

TA4F/TQG XLR Preamplifier	RPM400TQG
Lemo XLR Preamplifier	RPM400LEMO
Belt Clip for XLR Preamplifier	RPM40PRECLIP
Mounting Kit for XLR Preamplifier	RPM40PREMNT

# Optional Accessories

Magnet Mount  
 Rycote® Mini-WindJammer (Gray)  
 Accessory Kit for TL Microphones

RPM40MM  
 RPM40MWJ  
 RPM40KIT

Magnet Mount is available in Black (/B) and White (/W) options.

**Note:** Optional accessories are not furnished with -A models.

# Wiring and Termination

## Typical Wiring Table

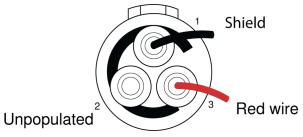
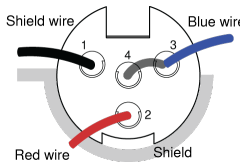
Series	Cable Construction	Electrical Design	Polarity	Replacement Connector	For Use With	Wiring	Line Art (From Solder Side)
TL45-LEMO	1.1mm cable with single conductor and shield	2-Wire (Common Source)	Negative with respect to ground	WA411	Shure Lemo Bodypacks (AD1/ADX1-Lemo, Shure UR1M-Lemo, ULXD1-Lemo), Sennheiser SK5212, Lectrosonics SSM, and others	Red wire: Audio/Bias(3)  Shield: Ground(1)	
TL46-MTQG, TL47-MTQG, TL48-MTQG	1.6mm cable with 2 conductors, 2 shield wires and shield	3-Wire (Source Follower)	Positive with respect to ground	WA430	All Shure TA4F Bodypacks	Red wire: Bias(2)  Blue wire: Audio(3)  Shield wire: Ground(1)  Shield: Ground (Shell)	

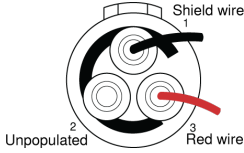
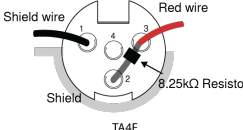
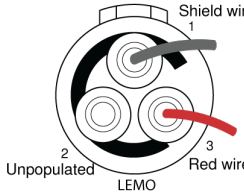
Series	Cable Construction	Electrical Design	Polarity	Replacement Connector	For Use With	Wiring	Line Art (From Solder Side)
TL46-LEMO, TL47-LEMO, TL48-LEMO	1.6mm cable with 2 conductors, 2 shield wires and shield	2-Wire (Common Source)	Negative with respect to ground	WA416	Shure Lemo bodypacks (ADX1-Lemo, Shure UR1M-Lemo, ULXD1-Lemo), Sennheiser SK5212, Lectrosonics SSM, and others	Red wire: Audio/Bias(3) Blue wire: Not connected Shield wire: Ground(1)	
TL47-NC, TL48-NC	1.6mm cable with 2 conductors, 2 shield wires and shield	2-Wire (Common Source)	Negative with respect to ground	LEMO: WA416, Shure TQG/ TA4F: WA430, Lectrosonics TA5F: WA435	Termination Dependent	Red wire: Audio/Bias Blue wire: Not connected Shield wire: Ground Shield: Ground (Shell)	 

## Converting LEMO to TA4F

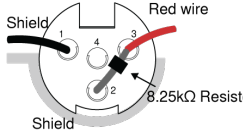
Series	Cable Construction	Electrical Design	Polarity	Replacement Connector	For Use With	Wiring	Line Art (From Solder Side)
TL45-LEMO	1.1mm cable with single conductor and shield	2-Wire (Common Source)	Negative with respect to ground	Shure TQG/ TA4F: WA430	Termination Dependent	Shield: Ground(1) Red wire: Audio/Bias(3) 8.25kΩ Resistor between pin 2 and 3	

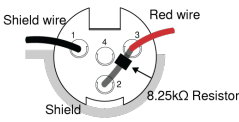
Series	Cable Construction	Electrical Design	Polarity	Replacement Connector	For Use With	Wiring	Line Art (From Solder Side)
TL46-LEMO, TL47-LEMO, TL48-LEMO	1.6mm cable with 2 conductors, 2 shield wires and shield	2-Wire (Common Source)	Negative with respect to ground	Shure TQG/TA4F: WA430	Termination Dependent	Shield: Ground(Shell)  Shield wire: Ground(1)  Red wire: Audio/Bias(3)  Blue wire: Not connected  8.25kΩ Resistor between pin 2 and 3  Shield: Ground(Shell)	

## TA5F Wiring for Lectrosonics Bodypacks (Servo Biased Wiring)

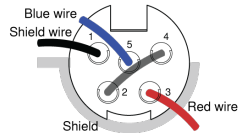
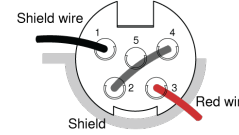
Series	Cable Construction	Electrical Design	Polarity	Replacement Connector	For Use With	Wiring	Line Art (From Solder Side)
TL46-MTQG, TL47-MTQG, TL48-MTQG	1.6mm cable with 2 conductors, 2 shield wires and shield	3-Wire (Source Follower)	Positive with respect to ground	WA435	Lectrosonics TA5F bodypacks	Red wire: Bias(3)  Blue wire: Audio(5)  Shield wire: Ground(1)  Shield: Ground(Shell)  Jumper between 2 and 4	
TL46-LEMO, TL47-LEMO	1.6mm cable with 2 conductors, 2 shield wires and shield	2-Wire (Common Source)	Negative with respect to ground	WA435	Lectrosonics TA5F bodypacks	Red wire: Audio/Bias(3)	

Series	Cable Construction	Electrical Design	Polarity	Replacement Connector	For Use With	Wiring	Line Art (From Solder Side)
--------	--------------------	-------------------	----------	-----------------------	--------------	--------	-----------------------------

TL48-LEMO, TL47-NC, TL48-NC

shield wires and shield

to ground

Blue wire:  
Not connected

Shield wire:  
Ground(1)

Shield:  
Ground(Shell)

Jumper between 2 and 4

### MTQG Connector Assembly

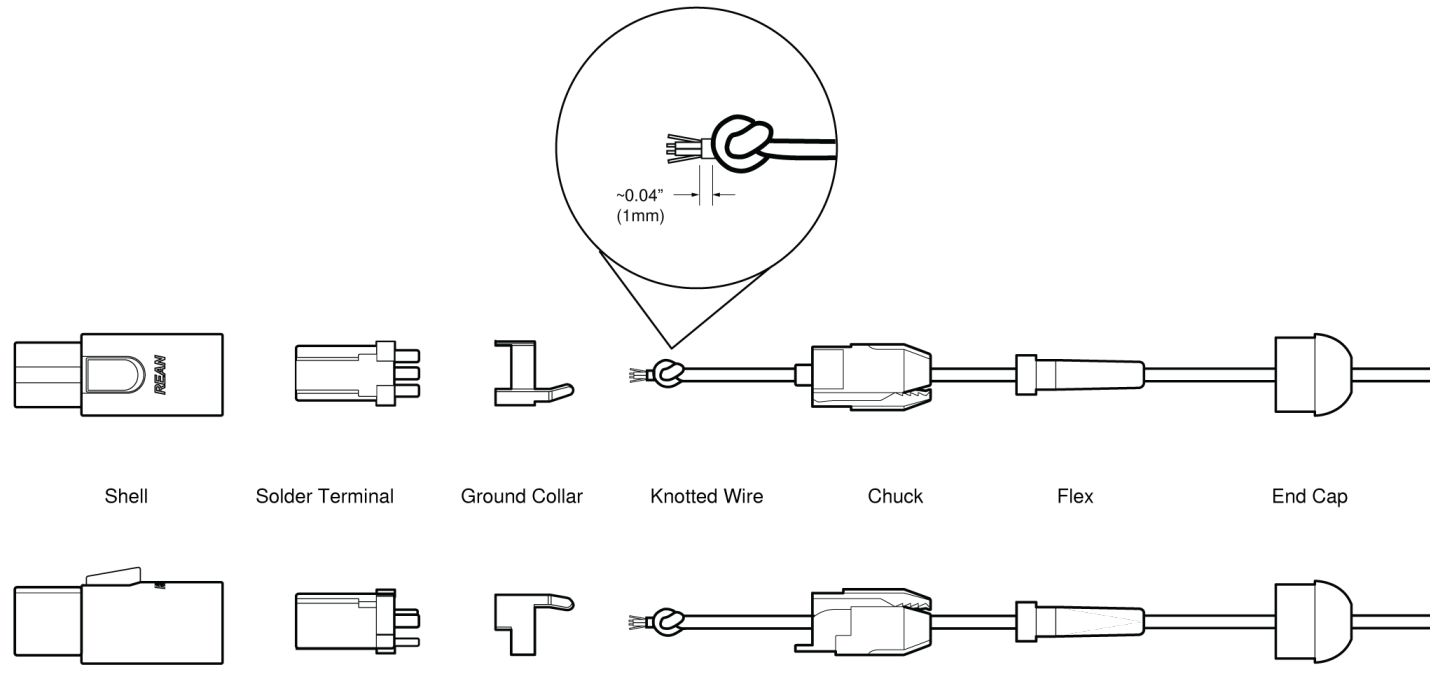

Exploded View

**Note:** Make sure to solder the shield to ground collar.

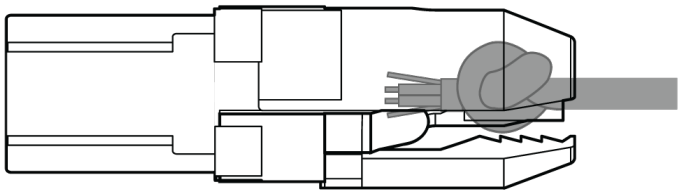

Assembled View

# RPM400 Preamplifiers

**The RPM400 preamplifiers offer exceptional dynamic range utilizing an active gain circuit in a concise and small package. They are offered in two connector versions: TA4F and LEMO, which allows you to quickly take a wireless TL microphone and make it a wired solution. These preamplifiers require phantom power and can efficiently operate across a wide range of supply voltages from 12-48v.**

## Features

- Active circuit design with neutral gain mimics wireless for consistent gain output across wired or wireless applications.
- High RF immunity against unwanted interference.
- Short, compact design.
- Belt clip and table mounting kits for easy placement for a variety of applications.

## Preamplifier Mounting Kit

TwinPlex XLR microphones include an under table mounting kit for temporarily or permanently mounting the amplifier. It includes preamplifier clip, 4 screws, and premium dual lock adhesive. The mounting kit and accessories are also sold separately.

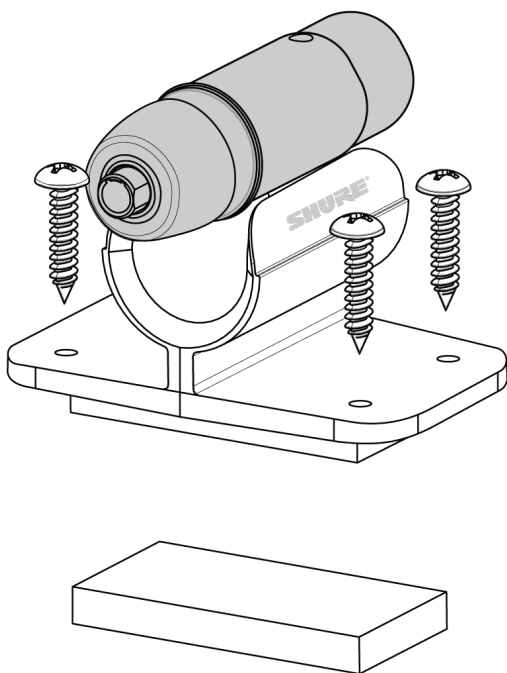



# Specifications

## Output Impedance

100  $\Omega$

## Connector

Three-pin professional audio (XLR), male, balanced

## Output Clipping Level

3.0 dBV, 1 kHz at 1% THD, typical

## Microphone Bias

5 V DC

## Polarity

Positive pressure on diaphragm produces positive voltage on pin 2 with respect to pin 3

## Sensitivity

TL46 into RPM400LEMO	-31.0 dBV(28.2 mV)at 1 kHz <sup>[2]</sup>
TL45, TL47, TL48 into RPM400LEMO	-39.0 dBV(11.2 mV)at 1 kHz <sup>[2]</sup>
TL46 into RPM400MTQG	-37.0 dBV(14.1 mV)at 1 kHz <sup>[2]</sup>
TL45, TL47, TL48 into RPM400MTQG	-45.0 dBV(5.62 mV)at 1 kHz <sup>[2]</sup>

## Maximum SPL <sup>[4]</sup>

TL46 into RPM400LEMO	128.0 dB SPL, 1 kHz at 1% THD, typical
TL45, TL47, TL48 into RPM400LEMO	136.0 dB SPL, 1 kHz at 1% THD, typical
TL46 into RPM400MTQG	134.0 dB SPL, 1 kHz at 1% THD, typical
TL45, TL47, TL48 into RPM400MTQG	142.0 dB SPL, 1 kHz at 1% THD, typical

## Dynamic Range

TL46 into RPM400LEMO	104.0 dB typical
TL45, TL47, TL48 into RPM400LEMO	111.5 dB typical
TL46 into RPM400MTQG	110.0 dB typical
TL45, TL47, TL48 into RPM400MTQG	117.5 dB typical

## Power Requirements

MTQG	11–52 V DC <sup>[1]</sup> phantom power, 4.8 mA
LEMO	11–52 V DC <sup>[1]</sup> phantom power, 5.5 mA

<sup>[1]</sup>All specifications measured with a 48 Vdc phantom power supply. The microphone operates at lower voltages, but with slightly decreased headroom and sensitivity.

<sup>[2]</sup><sub>1</sub> Pa=94 dB SPL

<sup>[3]</sup>S/N ratio is the difference between 94 dB SPL and equivalent SPL of self noise, A-weighted

<sup>[4]</sup>THD of microphone preamplifier when applied input signal level is equivalent to cartridge output at specified SPL

## Dimensions

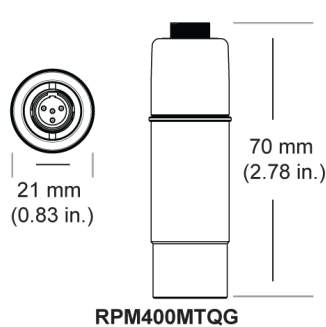
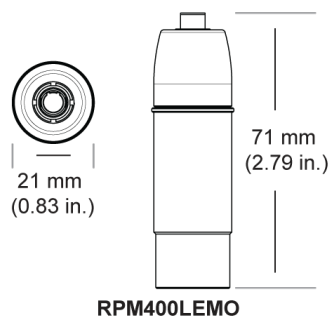

## Certifications

**Note:** Testing is based on the use of supplied and recommended cable types. The use of other than shielded (screened) cable types may degrade EMC performance.

The CE Declaration of Conformity can be obtained from: [www.shure.com/europe/compliance](http://www.shure.com/europe/compliance)

Authorized European representative:

Shure Europe GmbH

Headquarters Europe, Middle East & Africa

Department: EMEA Approval

Jakob-Dieffenbacher-Str. 12

75031 Eppingen, Germany

Phone: +49-7262-92 49 0

Fax: +49-7262-92 49 11 4

Email: [info@shure.de](mailto:info@shure.de)