

TL69专业晶体管电容话筒

TL69 Professional FET Condenser Microphone

用户手册

Owner's Manual

目录

中文

一、注意事项.....	2
二、产品概述.....	3
三、安装.....	3
四、XLR连接.....	4
五、灵敏度衰减开关.....	4
六、低频衰减.....	4
七、指向性切换.....	4
八、近讲效应.....	5
九、一般使用规则.....	5
十、规格.....	6
十一、频响曲线以及极性图.....	6
十二、提供的附件.....	6
十三、保修.....	6

English

1. PRECAUTIONS.....	7~8
2.GENERAL DESCRIPTION.....	8
3.MOUNTING.....	9
4.XLR CONNECTION.....	9
5.PAD SWITCH.....	9
6.LOW FREQUENCY ROLLOFF	10
7.POLAR PATTERN SWITCH.....	10
8.MICROPHONE TECHNIQUES.....	10
9.GENERAL RULES FOR USE.....	11
10.SPECIFICATIONS.....	11
11.THE FREQUENCY RESPONSE CURVES AND THE POLAR DIAGRAM.....	11
12.ACCESSOIRES.....	11
13.SERVICE.....	11

一、注意事项



警告

为了避免因触电、短路、损伤、火灾或其它危险可能导致的严重受伤甚至死亡，请务必遵守下列基本注意事项。这些注意事项包括但不限于下列情况：

电源/电源线

- 只能使用本设备所规定的额定电压。所要求的电压被印在本设备的铭牌上。
- 只能使用附带的电源线。
- 请勿将电源线放在热源如加热器或散热器附近，不要过分弯折或损伤电源线，不要在其上加压重物，不要将其放在 可能被踩踏引起绊倒或可能被碾压的地方。

当意识到任何异常情况时

- 若电源线出现磨损或损坏，使用设备过程中声音突然中断或因此而发出异常气味或冒烟，请立即关闭电源开关，从电源插座中拔出电源线插头，并请有资格的Alctorn维修人员对设备进行检修。
- 若本设备发生掉落或损坏，请立即关闭电源开关，从电源插座中拔出电源线插头，并请有资格的Alctorn维修人员对设备进行检修。



小心

为了避免您或周围他人可能发生的人生伤害、设备或财产损失，请务必遵守下列基本注意事项。这些注意事项包括但不限于下列情况：

电源/电源线

- 当准备长期不使用本设备或发生雷电时，请从电源插座中拔出电源线插头。
- 当从本设备或电源插座中拔出电源线插头时，请务必抓住插头而不是电源线。直接拽拉电源线可能会导致损坏。

安放位置

- 移动本设备之前，请先拔下所有连接的电缆。
- 为了避免操作面板发生变形或损坏内部组件，请勿将本设备放在有大量灰尘、震动、极端寒冷或炎热(如阳光直射，靠近加热器或烈日下的汽车里)的环境中。
- 请勿将本设备放在不稳定的地方，否则可能会导致突然翻倒。
- 请勿在电视机、收音机，立体声设备，手机或其他电子设备附近使用本设备。否则，本设备、电视机或收音机可能会产生噪音。

经常动态接触的零部件，如开关、控制旋钮、接口等，随着时间的推移，其性能会逐渐下降。请让有资格的Alctorn维修服务人员为您更换有缺陷的零部件。

当不使用本设备时，请务必关闭其电源。

请在操作试用前，首先仔细阅读下述内容

· 请将本说明书存放在安全的地方，以便将来随时参阅

关于潮湿的警告

- 请勿让本设备淋雨或在水附近及潮湿环境中使用，或将盛有液体的容器放在其上，否则可能会导致液体溅入任何开口。如果任何液体如水渗入本设备，请立即切断电源并从AC电源插座拔下电源线。然后请有资格的Alctorn维修人员对设备进行检修。
- 切勿用湿手插拔电源线插头口

请勿打开

- 请勿打开本设备并试图拆卸其内部零件或进行任何方式的改造。本设备不含任何用户可自行修理的零件。若出现异常，请立即停止使用，并请有资格的Alctorn维修人员进行检修。

连接

- 将本设备连接到其它设备之前，请关闭所有设备的电源开关。在打开或关闭所有设备的电源开关之前，请将所有音量都调到最小。

小心操作

- 请勿将手指或手插入本设备的任何间隙或开口。
- 请避免在设备上的任何间隙或开口插入或落进异物(纸张、塑料、金属等)。万一发生这种情况，请立即关闭电源开关，从AC电源插座中拔出电源插头。然后请有资格的Alctorn维修人员进行检修。
- 请勿将身体压在本设备上或在其上放置重物，操作按钮、开关或插口时要避免过分用力。

XLR型插口应按下图所示进行布线(IEC60268标准)：针1：地线，针2：热线(+)和针3：冷线(-)。

对于由于正常使用或擅自改造本设备所造成的损失、数据丢失或破坏，Alctorn不负任何责任。

二、产品概述

爱克创TL69采用了35mm 镀金大振膜音头和无变压器线路设计，其通透优美的高频和细腻的低频使其成为录制人声最好的选择！通过调节3个指向性开关 可以使其适应各种录音环境并能达到最好的音质，其他特点还包括低切和灵敏度衰减开关。

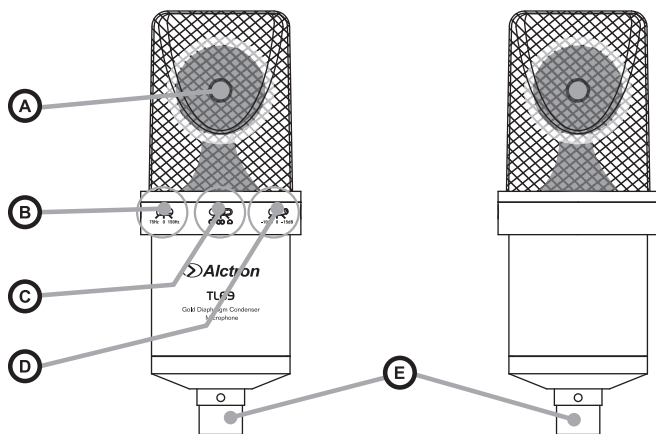

A	话筒音头	35MM镀金大振膜。
B	低频衰减开关	75Hz或者150Hz以下每倍频程衰减6dB
C	指向性切换开关	能够在不同场合下以不同的指向性使用
D	灵敏度衰减开关	用来防止拾取极高声源时出现削波。
E	XLR接口	话筒电平输出

三、安装

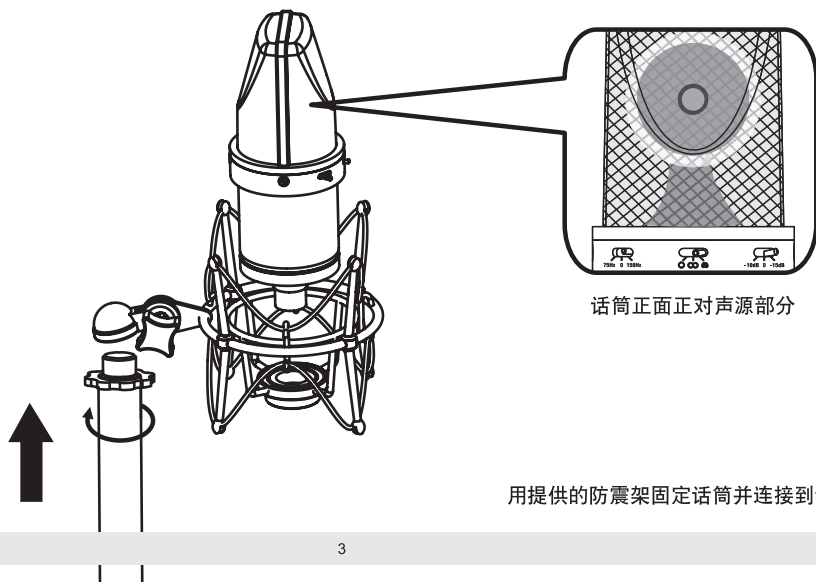

用提供的防震架固定话筒并连接到话筒架。

四、XLR连接

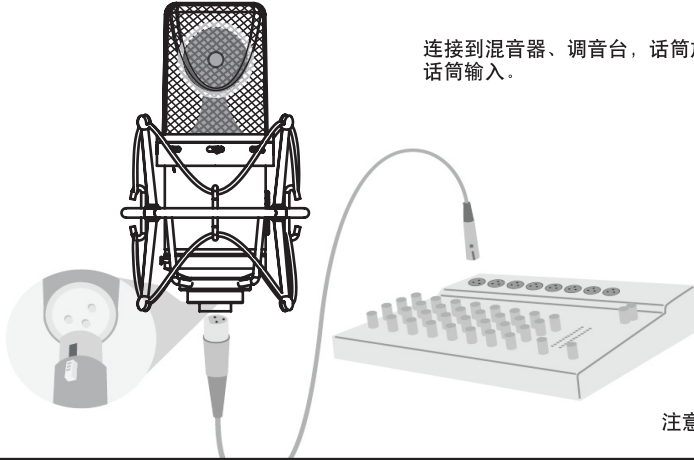

连接到混音器、调音台，话筒放大器或其它设备上的话筒输入。

注意：必须开启幻象供电。

五、灵敏度衰减开关

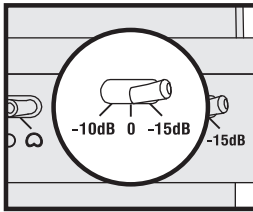

衰减开关帮助防止极高声源的失真，例如近场拾取号声或鼓声。

六、低频衰减

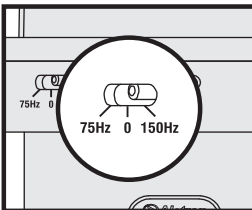

低频衰减可用来处理人声或中音至高音范围的乐器。它可减少暖气或空调系统发出的低频室内噪声和地板震动引起的噪声。此外，还可用来补偿近讲效应，或减少使乐器声变得低沉或浑浊的低频。

七、指向性切换：

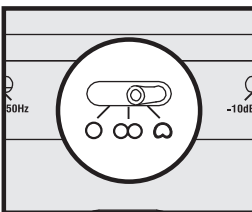

指向性切换能够使话筒在不同的场合下发挥不同的用途。TL69有3种指向性，从左到右分别为：全指向、8字型指向，心型指向。

八、近讲效应

当话筒与声源之间的距离在6毫米（1/4英寸）左右时，像BC400这样的指向性的话筒会将100HZ以下的低频提升6-10dB,这个现象被称之为“近讲效应”，在录音时，常会被用来创造一种更加温暖，更加厚重的音色效果。

运用	建议话筒放置位置	音质
人声	嘴与防风罩的距离少于15 厘米（6 英寸），或轻触防尘罩，在话筒轴线上。	饱满、加重低音、最大程度隔离其它声源。
	与嘴的距离为 15 至 60 厘米（6 英寸至 2 英尺），刚好在鼻子平面上面。	自然，减弱低音。
	与嘴的距离为 20 至 60 厘米（8 英寸至 2 英尺），稍微偏向一侧。	自然、减弱低音和 "s" 声。
	距离 90 厘米至 1.8 米（3 至 6 英尺）	薄的远距离声音；可听见不同程度的环境声。
电吉他 电贝司音箱	与扬声器的距离为 2.5 厘米（1 英寸），在话筒轴线上扬声器锥盆范围内。	音头锐利；低频突出。
	与扬声器的距离为 2.5 厘米（1 英寸），在扬声器锥盆边缘。	音头锐利；低频突出。
	离扬声器 15 至 30 厘米（6 至 12 英寸），在话筒轴线上扬声器锥盆范围内。	音头平和；完整的平衡声。
	与扬声器的距离为 60 至 90 厘米（2 至 3 英尺），在话筒轴线上扬声器锥盆范围内。	音头柔软；低频减弱。

九、一般使用规则

将话筒对准所录制的声源（例如谈话者、唱歌者或乐器），远离其他声源。

尽可能靠近所录制声源摆放。

如果想获得更多的低频响应，可将话筒进一步靠近声源。

只使用一个话筒来拾取单个声源。

尽可能减少使用话筒的数量。

保持话筒之间的距离，使其至少三倍于每个话筒与其声源之间的距离。

将话筒放置在尽可能远离反射表面的地方。

在户外使用话筒时，加一个防风罩。

避免过多触摸，以便将机械噪声的拾取和震动降低到最低水平。

切勿用手遮盖住话筒滤网的任何部位，因为这会影响到话筒的性能。

应让话筒保持干燥，并避免暴露在极高温度和湿度下。

严禁向话筒音头部位吹气，请勿拍打话筒。

十、规格

- * 音头: 35MM镀24K纯金大振膜音头
- * 指向性: 心形,圆形,8字形
- * 开关: 低切开关,灵敏度衰减开关, 指向性切换开关
- * 频率响应: 20Hz-20kHz
- * 灵敏度: $-38\text{dB} \pm 2\text{dB}$ ($0\text{dB}=1\text{V}/\text{Pa}$)
- * 输出阻抗: $\leq 200\ \Omega$
- * 等效噪音: 20dB A
- * 连接器: 3芯卡侬连接线
- * 电源: 48V幻相电源

十一、频响曲线以及极性图

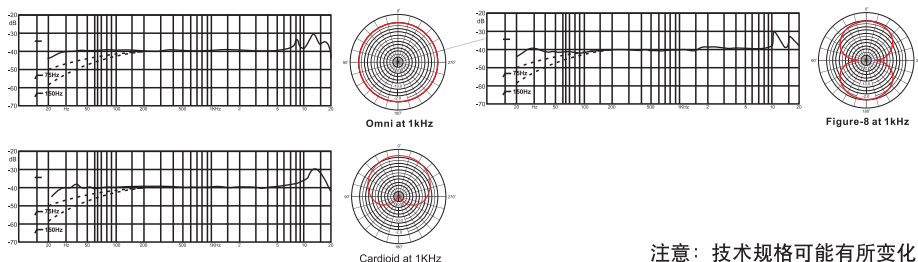

注意：技术规格可能有所变化。

十二、提供的附件



铝箱



木盒



皮袋

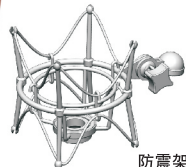

防震架



防风罩

十三、保修

如果您的话筒需要维修，请按照以下说明操作。

1. 请确保不是因为操作不当或外部设备所造成。
2. 请保存好我们的说明书，返修的时候不必把说明书寄回给我们。
3. 返修的时候请用产品原来的包装箱来包装，这是非常重要的。如果你已丢失原包装，请确保您正确包装和保护好本耳机。ALCTRON是不负责由于非原厂包装造成任何损害。
4. 运送到ALCTRON技术支持中心或当地的授权经销商。

Alctron公司始终尽力确保最高的质量水平。必要的修改将不预先通知予以实行。因此产品的技术数据和外观可能与所述说明或插图有不同之处，敬请谅解。

宁波市鄞州奥创电子有限公司 地址：浙江省宁波市鄞州区秀丰工业区三成路76号 电话：++86 574 88009874
 传真：0574-87157176 邮箱：sales@alctron-audio.com 网址：http://www.alctron-audio.com
 全国统一服务热线：4000-160-112

1. PRECAUTIONS

PLEASE READ CAREFULLY BEFORE PROCEEDING

* Please keep this manual in a safe place for future reference.



WARNING

Always follow the basic precautions listed below to avoid the possibility of serious injury or even death from electrical shock, short-circuiting, damages, fire or other hazards. These precautions include, but are not limited to, the following:

Power supply/Power cord

- Only use the voltage specified as correct for the device. The required voltage is printed on the name plate of the device.
- Use only the included power cord.
- Do not place the power cord near heat sources such as heaters or radiators, and do not excessively bend or otherwise damage the cord, place heavy objects on it, or place it in a position where anyone could walk on, trip over, or roll anything over it.

Do not open

- Do not open the device or attempt to disassemble the internal parts or modify them in any way. The device contains no user-serviceable parts. If it should appear to be malfunctioning, discontinue use immediately and have it inspected by qualified ALCTRON service personnel.

Water warning

- Do not expose the device to rain, use it near water or in damp or wet conditions, or place containers on it containing liquids which might spill into any openings.
- Never insert or remove an electric plug with wet hands.

If you notice any abnormality

- If the power cord or plug becomes frayed or damaged, or if there is a sudden loss of sound during use of the device, or if any unusual smells or smoke should appear to be caused by it, immediately turn off the power switch, disconnect the electric plug from the outlet, and have the device inspected by qualified ALCTRON service personnel.
- If this device should be dropped or damaged, immediately turn off the power switch, disconnect the electric plug from the outlet, and have the device inspected by qualified ALCTRON service personnel.



CAUTION

Always follow the basic precautions listed below to avoid the possibility of physical injury to you or others, or damage to the device or other property. These precautions include, but are not limited to, the following:

Power supply/Power cord

- Remove the electric plug from the outlet when the device is not to be used for extended periods of time, or during electrical storms.
- When removing the electric plug from the device or an outlet, always hold the plug itself and not the cord. Pulling by the cord can damage it.

Location

- Before moving the device, remove all connected cables.
- Do not expose the device to excessive dust or vibrations, or extreme cold or heat (such as in direct sunlight, near a heater, or in a car during the day) to prevent the possibility of panel discoloration or damage to the internal components.
- Do not place the device in an unstable position where it might accidentally fall over.
- Do not use the device in the vicinity of a TV, radio, stereo equipment, mobile phone, or other electric devices. Otherwise, the device, TV, or radio may generate noise.

Water warning

- Before connecting the device to other devices, turn off the power for all devices. Before turning the power on or off for all devices, set all volume levels to minimum.

Handling caution

- Do not insert your fingers or hand in any gaps or openings on the device.
- Avoid inserting or dropping foreign objects (paper, plastic, metal, etc.) into any gaps or openings on the device. If this happens, turn off the power immediately and unplug the power cord from the AC outlet. Then have the device inspected by qualified ALCTRON service personnel.
- Do not rest your weight on the device or place heavy objects on it, and avoid use excessive force on the buttons, switches or connectors.

XLR-type connectors are wired as follows (IEC60268 standard): pin 1: ground, pin 2: hot (+), and pin 3: cold (-).

ALCTRON Cannot be held responsible for damage caused by improper use or modifications to the device.

Always turn the power off when the device is not in use.

The performance of components with moving contacts, such as switches, volume controls, connectors, and fans, deteriorates over time.

Consult qualified ALCTRON service personnel about replacing defective components.

European models

Purchaser/User Information specified in EN55103-1 and EN55103-2. Inrush Current: 2 A

Conforms to Environments: E1, E2, E3 and E4

2. GENERAL DESCRIPTION

The TL69 offers high powerful, rich and smooth low frequency, 35mm large gold diaphragm capsule and high-power transformerless electronics deliver the vocal impact you deserve.

Three polar patterns let you balance tone and space. Additional features include hi-pass filter, attenuator and power switch. It is your perfect choice for any of recording, broadcasting and other stage application.

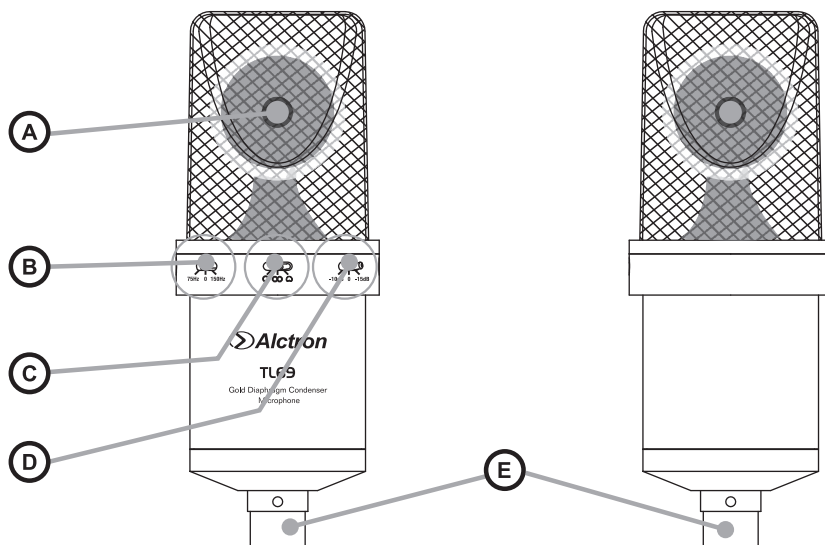

A	Microphone Capsule:	1.34-inch (35 mm) large gold-sputtered diaphragm
B	Low-frequency roll-off:	12 dB-per-octave below 75Hz or 200 Hz.
C	Polar Pattern Switch	Use for recording in different situations
D	Pad Switch:	Use to prevent clipping from extremely loud sound sources.
E	XLR Connector:	Microphone-level output

3. MOUNTING

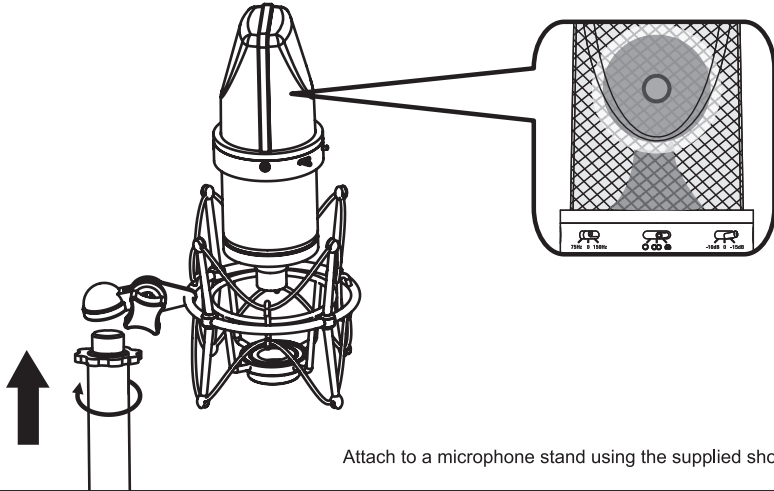

Attach to a microphone stand using the supplied shock mount.

4. XLR CONNECTION

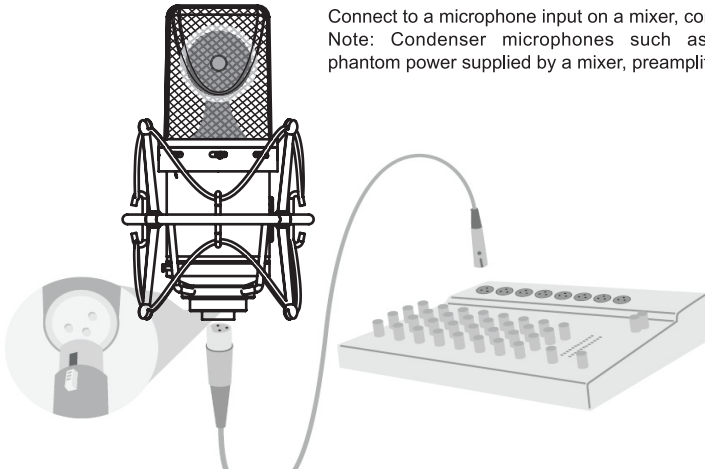

Connect to a microphone input on a mixer, console, or other device. Note: Condenser microphones such as the TL69 require phantom power supplied by a mixer, preamplifier, or console.

5. PAD SWITCH

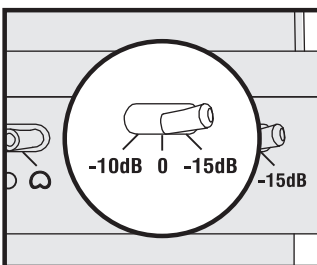

The pad switch helps prevent distortion from extremely loud sources, such as when close-miking horns or drums.

6. LOW FREQUENCY ROLLOFF

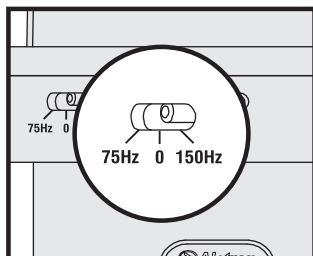

The low frequency rolloff may be used for voice or medium- to high-range instruments. It reduces floor rumble and low-frequency room noise from heating and air conditioning systems. Also used to compensate for proximity effect or to reduce low frequencies that make an instrument sound dull or muddy.

7. POLAR PATTERN SWITCH

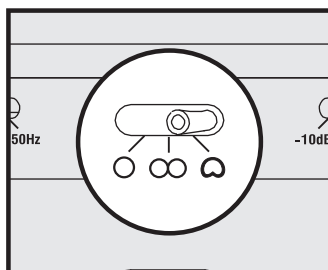

With Polar Pattern Switch, the microphone to be used in different TL69 has three polar patterns: Omni, Figure 8 and Omni (From left to right)

8. MICROPHONE TECHNIQUES

APPLICATION	SUGGESTED MICROPHONE PLACEMENT	TONE QUALITY
Vocals	Lips less than 15 cm (6 in.) away or touching the windscreen, on axis to microphone.	Robust sound, emphasized bass, maximum isolation from other sources.
	15 to 60 cm (6 in. to 2 ft.) away from mouth, just above nose height.	Natural sound, reduced bass.
	20 to 60 cm (8 in. to 2 ft.) away from mouth, slightly off to one side.	Natural sound, reduced bass and minimal "s" sounds.
	90 cm to 1.8 m (3 to 6 ft.) Away.	Thinner, distant sound; noticeable levels of ambient noise.
Guitar & Bass Amplifiers	2.5 cm (1 in.) from speaker, on-axis with center of speaker cone.	Sharp attack; emphasized bass.
	2.5 cm (1 in.) from speaker, at edge of speaker cone.	Sharp attack; higher frequency sound.
	15 to 30 cm (6 to 12 in.) away from speaker and on-axis with speaker cone.	Medium attack; full, balanced sound.
	60 to 90 cm (2 to 3 ft.) back from speaker, on-axis with speaker cone.	Softer attack; reduced bass.

9. GENERAL RULES FOR USE

Aim the microphone toward the desired sound source (such as the talker, singer, or instrument) and away from unwanted sources.

Place the microphone as close as practical to the desired sound source.

Work close to the microphone for extra bass response.

Use only one microphone to pick up a single sound source.

Use the fewest number of microphones as practical.

Keep the distance between microphones at least three times the distance from each microphone to its source.

Place microphones as far as possible from reflective surfaces.

Add a windscreen when using the microphone outdoors.

Avoid excessive handling to minimize pickup of mechanical noise and vibration.

Do not cover any part of the microphone grille with your hand, as this will adversely affect microphone Performance.

10. SPECIFICATIONS

- * Type: Multi-Pattern Condenser
- * Capsule : 35mm gold dual-diaphragm capsule
- * Polar patterns : cardioid, omni, and figure 8
- * Low cut filter: features 6dB octave @ 75Hz, 150Hz
- * Attenuator: -10dB, -20dB sensitivity pads
- * Frequency response: 20Hz - 20KHz
- * Sensitivity: $-34 \pm 2\text{dB}(\text{odB}=1\text{V/Pa})$
- * Out put Impedance: $\leq 200\ \Omega$
- * Equivalent Noise Level: 11dB equivalent SPL, A weighted
- * Max SPL: 148dB SPL (with pad on)
- * Connector: Gold plated 3-Pin XLR
- * Power Requirement: 48V phantom power supply

11. FREQUENCY RESPONSE

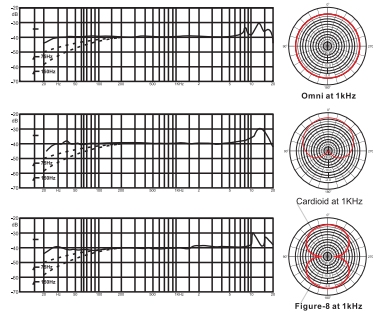

12. ACCESSOIRES



Other Multi-func



Wooden Box

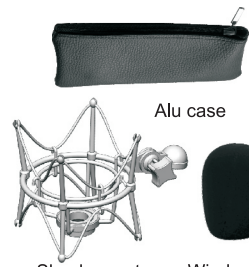

Alu case

Shockmount

Windscreen

13. SERVICE

If your Microphone needs servicing, follow these instructions.

1. Ensure the problem is not related to operation error or external system devices.
2. Keep this owner's manual. We don't need it to repair the unit.
3. Pack the unit in its original packaging including end card and box. This is very important. If you have lost the packaging, please make sure you have packed the unit properly. ALCTRON is not responsible for any damage that occurs due to non-factory packing.
4. Ship to the ALCTRON tech support center or the local return authorization.

ALCTRON is constantly striving to maintain the highest professional standards. As a result of these efforts, modifications may be made from time to time to existing products without prior notice. Specifications and appearance may differ from those listed or illustrated.