



# SP<sup>®</sup> 218P

Powered Speaker System

---

## Product Specifications





## FCC/ICES Compliancy Statement

This device complies with Part 15 of the FCC rules and Industry Canada license-exempt RSS Standard(s). Operation is subject to the following two conditions: (1) this device may not cause harmful interference, and (2) this device must accept any interference received, that may cause undesired operation.

Le présent appareil est conforme aux CNR d'Industrie Canada applicables aux appareils radio exempts de licence. L'exploitation est autorisée aux deux conditions suivantes: (1) l'appareil ne doit pas produire de brouillage, et (2) l'utilisateur de l'appareil doit accepter tout brouillage radioélectrique subi, même si le brouillage est susceptible d'en compromettre le fonctionnement.

**Warning:** Changes or modifications to the equipment not approved by Peavey Electronics Corp. can void the user's authority to use the equipment.

**Note** – This equipment has been tested and found to comply with the limits for a Class B digital device, pursuant to Part 15 of the FCC Rules. These limits are designed to provide reasonable protection against harmful interference in a residential installation. This equipment generates, uses, and can radiate radio frequency energy and, if not installed and used in accordance with the instructions, may cause harmful interference to radio communications. However, there is no guarantee that interference will not occur in a particular installation. If this equipment does cause harmful interference to radio or television reception, which can be determined by turning the equipment off and on, the user is encouraged to try and correct the interference by one or more of the following measures.

- Reorient or relocate the receiving antenna.
- Increase the separation between the equipment and receiver.
- Connect the equipment into an outlet on a circuit different from that to which the receiver is connected.
- Consult the dealer or an experienced radio/TV technician for help.

## Caution

The equipment complies with FCC radiation exposure limits set forth for an uncontrolled environment.



## **SP®218P**

### **Introduction**

Thank you for purchasing the Peavey® SP® 218P Sub powered speaker system. The SP® 218P Sub features a power section that provides 2,000 watts of peak power, with DDT™ compression. Featuring two Peavey® exclusive 18” Pro Rider™ woofers in a sturdy plywood enclosure, the SP® 218P Sub provides two mixed input channels, each with Gain control and a mic/line gain switch, and each channel features a combo jack with 1/4” TRS & female XLR and a balanced input, with volume control. A DSP based crossover and processor provides extreme flexibility to the user faced with common location acoustics conditions.

- **VENTED BASS POWERED SUBWOOFER ENCLOSURE**
- **2,000 WATTS PEAK AVAILABLE POWER**
- **TWO PEAVEY® EXCLUSIVE PRO RIDER™ 18” WOOFERS**
- **POWER AMP HAS FORCED AIR COOLING FOR MAXIMUM RELIABILITY**
- **POWERFUL YET PRECISE DSP BASED CROSSOVER NETWORK AND SPEAKER PROCESSING**
- **DSP BASED LIMITER FOR WOOFER PROTECTION**
- **24 BIT ADC/DAC, 96 KHZ SAMPLE RATE, 32 BIT FIXED POINT DSP**
- **TWO CHANNELS WITH XLR/ONE QUARTER INCH COMBO JACK INPUTS**
- **TWO XLR OUTPUTS, ONE HIGH-PASS, ONE FULL RANGE THRU**
- **FULL-COVERAGE HEAVY-DUTY PERFORATED STEEL GRILL**
- **TWO METAL HANDLES, ONE EACH SIDE, AND TOP REAR CORNER HANDLE**
- **TILT-BACK CASTERS FOR EASE OF TRANSPORT.**
- **THREADED POLE MOUNT WITH SPEAKER POLE INCLUDED**

### **Description**

The Peavey® SP® 218P Sub is a vented powered subwoofer system utilizing two Peavey® exclusive Pro Rider™ 18” woofers, coupled to a power amplifier with 2,000 watts peak available power. The full-length black perforated steel grille provides protection and a professional appearance, along with the steel handles and tilt-back casters for transport.

Internal line-level crossover with two outputs, independently electrically buffered; one full-range thru output, and one high-pass output.

A threaded pole-mount system provides a sturdy and stable platform to mount a suitably equipped speaker system above the sub woofer. Either the SP®2P or the SP®4P two-way powered speakers are an excellent partner for the SP® 218P Sub

The SP® 218P Sub speaker system power amplifier providing the power is a low-distortion ultra-reliable fan-cooled unit providing 2,000W peak available power for the system. The power supply for the power amp is a switch mode type for low weight and high efficiency. The amplifier features our DDT™ compression, which virtually eliminates audible power amplifier clipping. Cooling is provided via a low-noise fan, for reliable operation under any conditions.

Input is via two channels of a combo female XLR and 1/4” TRS phone jack with balanced input to the preamp/EQ electronics, and a level control.

The internal speaker crossover and processor is implemented with a high-performance DSP system. Using 24 bit ADC's and DAC's operating at 96 kHz, the 32 bit fixed point DSP processor provides all the filtering and EQ functions to allow the subwoofer to operate at it's best. DSP based limiting works in conjunction with the DDT™ compression to improve woofer reliability without intruding into the musical performance. An LCD display shows what functions or presets have been selected, these functions are selected via a push-to-select rotary knob.

A High-Pass output provides a buffered and balanced output signal for a satellite speaker to carry the high

range of the music, via a male XLR jack. A Full-Range Thru output has a male XLR connector. This output allows linking of additional speaker systems, or feed of the signal to other devices, etc.

## Applications

The Peavey SP® 218P Sub has a variety of applications such as extending the bass performance of smaller full-range speaker systems used for sound reinforcement, public address, side fill system, karaoke or musical playback. A typical signal source for the line-level inputs of the Peavey SP® 218P Sub would be a sound reinforcement mixing console (mixer) or the output from a CD player, MP3 player or tape deck. The high-pass filtered signal from SP® 218P Sub would then be sent to a full-range powered speaker system, easing the burden of deep bass from this speaker system.

## Bottom Rear Panel

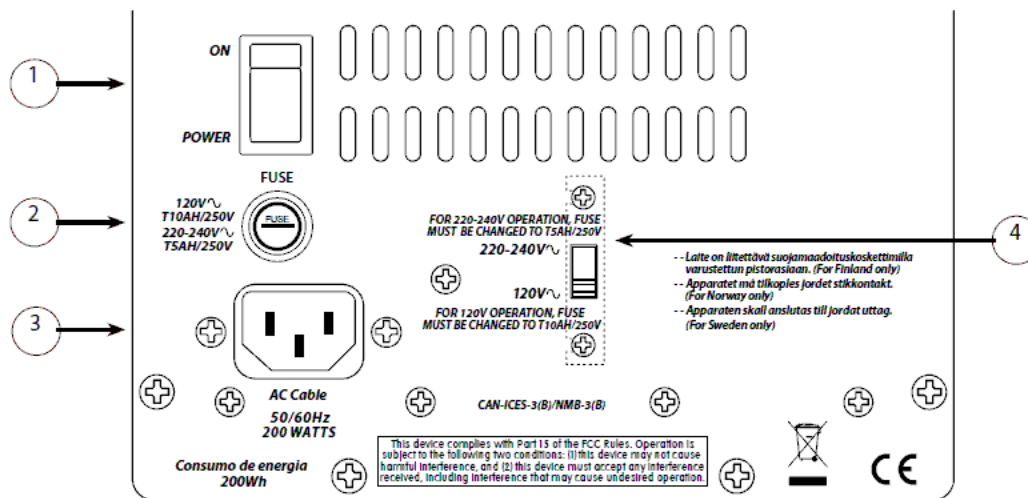

### ON-OFF SWITCH (1)

⚡ This rocker switch supplies AC power to the SP® 218P Sub when switched to the ON position. The ON position is with the top side of the switch pushed “in” or nearly flush with the rear panel.

### FUSE (2)

⚡ The unit is AC power line fuse protected from overloads and fault conditions with a slow-blow 5 x 20mm 250V fuse. This fuse is located within the cap of the fuse holder. If the fuse fails, **THE FUSE MUST BE REPLACED WITH THE SAME TYPE AND VALUE IN ORDER TO AVOID DAMAGE TO THE EQUIPMENT AND TO PREVENT VOIDING THE WARRANTY!**

The fuse in the SP® 218P Sub can be replaced with a time-delay type 5 x 20 mm size 250V rated fuse.

For 120VAC operation, a fuse rated at 10 amps should be used. In the USA, types GDC, GMC, 215, 218, and 477 cartridge-style 5 x 20 mm size fuses with a 10 amp 250V rating can be used.

For 220-240VAC operation, a fuse rated at 5 amps and 250V should be used, which conforms to the international fuse classification “T5AH”.

If the unit continues to blow replacement fuses, do not keep replacing them, it should be taken to a qualified service center for repair.

To replace the fuse, be sure to remove the IEC power cord from the IEC socket.



**IEC POWER CORD CONNECTION (3)** This receptacle is for the IEC line cord (supplied) that provides AC power to the unit. It is very important that you ensure the SP®218P has the proper AC line voltage supplied. You can set the proper voltage for your SP®218P using the Voltage Selector switch (4) on the rear panel of the unit.



Please read this guide carefully to ensure your personal safety as well as the safety of your equipment. Never break off the ground pin on any equipment. It is provided for your safety. If the outlet used does not have a ground pin, a suitable grounding adapter should be used and the third wire should be grounded properly. To prevent the risk of shock or fire hazard, always be sure that the mixer and all other associated equipment are properly grounded.



### **VOLTAGE SELECTOR SWITCH (4)**

The SP® 218P Sub has a voltage selector switch to allow switching between an input power voltage of 120VAC to a range from 220VAC to 240VAC, all at either 50 or 60 cycles per second (Hz). It should be set to the proper voltage for your country out of the box. However, world conditions are such that some areas have power line voltages differing from the voltage used by the majority of any given locale.



Be sure to check the position of the voltage selector switch to see that it matches the power line voltage used locally. If it does not match, then to change the voltage to the correct one, follow the steps outlined below.

### **Changing the Voltage Range of the SP®218P**

First, make sure the SP® 218P Sub is disconnected from the power line, and that the power switch (1) is in the OFF position.

Second, unscrew the screws holding the clear switch protector on the voltage selector switch (4) just a little, just enough to allow rotation of the clear switch protector. The screws DO NOT need to be unscrewed very far.

Third, rotate the clear plastic protector about 90 degrees to uncover the voltage selector switch. One side of the cover has a slot, the other just a hole, the side with the hole is the side that pivots.

Fourth, using a small flat blade screwdriver, push the red selector switch slide plate to the other side from where it was. The voltage that is now visible on the red slide plate is the one you have selected.

Fifth, rotate the clear plastic protector back underneath the loosened screws, and tighten one down while holding the clear plastic protector in place. Tighten the other screw down, and make sure both screws are tight.

If the screws are over-tightened, this could damage the voltage selector switch clear plastic cover, so do not apply excessive force to the screws!

Sixth, the fuse should be changed to the correct amperage rating. For an input power voltage of 120VAC, use a 10 amp rated, 250V 5 x 20 mm cartridge type time-delay fuse, which conforms to the international fuse classification "T10AH".

For an input power voltage range of from 220VAC to 240VAC, use a 5 amp rated, 250V 5 x 20 mm cartridge type time-delay fuse, which conforms to the international fuse classification "T5AH".

The IEC power cord that is correct for your locale can now be plugged into the IEC receptacle (3), and the Power switch (1) activated to turn on the powered SP® 218P Sub speaker system.

## Top Rear Panel

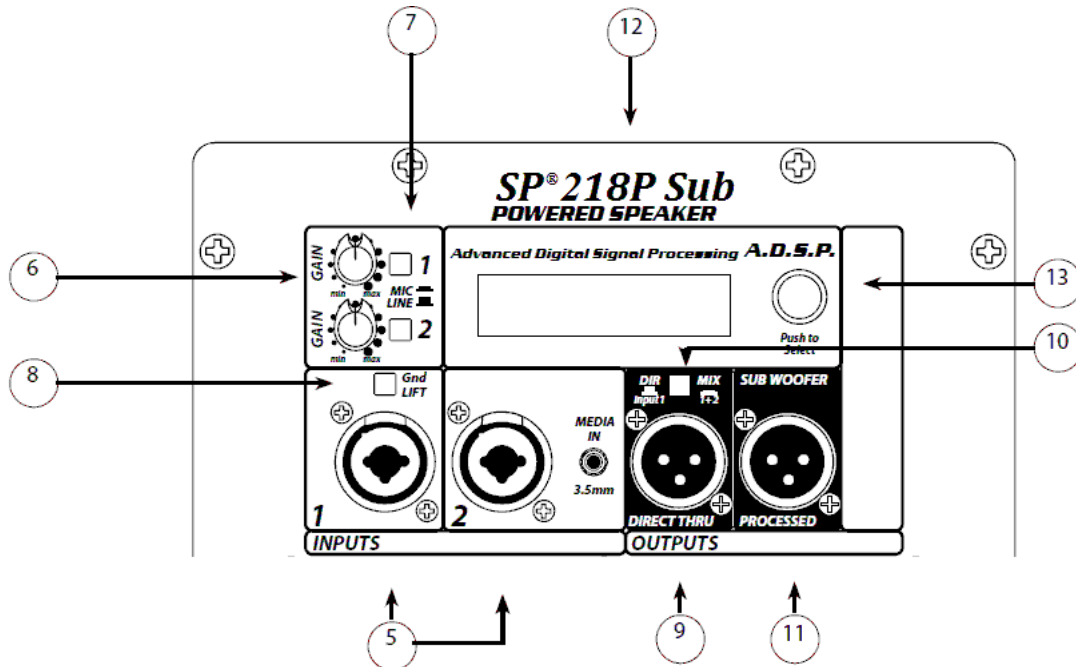

### INPUTS (5)

Two input channels are provided. The line-level input is of the medium impedance balanced type. The jack is a combo female XLR and 1/4" TRS connector. Sensitivity of this input is 0.42 volts for full output, when the MIC/LINE switch (7) is in the LINE position. Channel 2 has a 3.5 mm input jack for mobile device signal sources.

### GAIN CONTROLS (6), Present on both input Ch 1 and input Ch 2

Controls the gain or output level of the same numbered input channel. It is used to directly set the system output level for a given input signal.

### MIC/LINE switch (7), Present on both input Ch 1 and input Ch 2

Switches between LINE level gain (out position) and MIC level gain (in position). MIC position increases gain 26 dB to allow use of most dynamic microphones.

NOTE: Phantom power is not supplied on the INPUT (5) jacks

### Gnd LIFT switch (8)

Allows the shield to be disconnected from the chassis ground to alleviate hum from ground loops

### DIRECT THRU output jack (9)

This jack is intended for the use of linking multiple SP®218P Sub's in a line, or to provide a feed to a powered subwoofer, or other electronics that needs to receive a full range version of the input signal.

### DIR/MIX switch (10)

Switches between Direct Thru from channel 1 input, or a mix of channel 1 and channel 2 at the Direct Thru output (9)

### **HIGH PASS PROCESSED output jack (11)**

Provides a filtered signal for use with full-range powered speaker systems like the SP® 2P or SP® 4P. Follow the instructions in the Setup Wizard in the SP® 218P Sub menu on the LCD screen using the Push-To-Select button for proper set-up and connections. Or see the section titled: “ALTERNATE METHOD OF CONNECTING A SATELLITE SPEAKER TO THE SUB”.

### **LCD Display (12)**

Provides a menu read-out manipulated and activated by the Push-To-Select button (13)

### **Push-To-Select button (13)**

Rotary knob that allow the user to select and choose menu options on the LCD display screen (12). Pushing the button in till it detents makes a menu choice, selecting the action or option highlighted in the LCD screen.

## Safety Information

### **Cautions**

 The unit must be disconnected from the AC power source before any work is done on it. Refer all servicing to qualified service personnel.

The back plate can become hot to the touch. Do not block or cover the fan or the exhaust louvers from ventilation. There must be a minimum of 4” of space behind the fan. Do not allow the airflow to be become blocked by objects such as curtains or drapes, thermal building insulation, etc. It is recommended that the rear of the SP® 218P Sub not be placed in a closed space or a space that has no fresh, cool airflow.

Be sure to keep the microphone away from the front of the speaker after connecting it to the input, and while setting the microphone level, or very loud feedback will occur! Damage to the system is likely if this occurs!

 **DO NOT** connect the inputs of the SP® 218P Sub to the output of a power amplifier. The inputs are meant to be driven from a line-level strength signal.

**DO NOT** remove the protective metal grille.

 **WARNING!** The SP® 218P Sub is very efficient and powerful! This sound system can permanently damage hearing! Use extreme care setting the overall maximum loudness!

The apparent sound level of the SP® 218P Sub can be deceiving due to its clear, clean sound output. The lack of distortion or obvious distress can make the sound level seem much lower than it actually is. This system is capable of SPL in excess of 131 dB at 1 M from the speaker!

### **Transporting the SP® 218P Sub**

Two metal handles, one each side allow the SP® 218P Sub to be picked up and transported. A rear corner handle and tilt-back casters provide for rolling transport on smooth surfaces. Large rubber feet on the front bottom provide for a buzz free foundation for the Sub sitting on a wooden or tile floor.

### **Connecting AC Power To The SP® 218P Sub**

The SP® 218P Sub comes with an 6-foot IEC connection AC power cord. If you are using an extension cord or power strip with this powered speaker, make sure it is of good quality and of a sufficient current capacity to maintain safety and maximize the power output capability of the SP® 218P Sub. For maximum undistorted output, do not connect any other device to the same extension cord that the SP® 218P Sub is connected to. Do not

exceed the rated current capacity of the extension cord with the sum total of all units connected to it. When first plugging in the AC cord, make sure the power switch is in the Off position, and then turn it On only once the power cord has been connected. Built-in muting will engage when the proper sequence of steps is taken.

### **Special Note for Permanent Installation**

When installing the SP® 218P Sub, AC power runs will be used and a certified electrician should be consulted to be sure that all AC wiring complies with local codes and regulations. It is also advisable to use a cable clip properly affixed to the cabinet to strain relief the IEC power cord connected to the amplifier module at (3) so the power cord cannot be pulled out or vibrate loose.

### **Use of the SP® 218P Sub Speaker Pole**

The SP® 218P Sub has a threaded pole mount cup built-in so that the system can stand mount a full-range speaker on a supplied 1 3/8" (35mm) diameter stand pole with an M20 threaded end.

When using the speaker pole, be sure to follow these precautions:

- A. The pole is rated for use with a speaker that is less than 32 inches high, and less than 60 lbs.
- B. Always place the Sub on a flat, level and stable surface.
- C. Try to route cables so that people will not trip over them, or tip the speaker over. Use of duct tape, cable channels or guards, or other appropriate tie-down/cover-up devices should be carefully considered and implemented.
- D. When installing or de-installing the speaker on the pole, it is a good practice to have a helper if possible, it can be hard to "thread the needle" and mate the full-range speaker stand cup to the Sub pole while holding the full-range speaker system at arm's length.
- E. When using Subs with poles outdoors, never attach banners or flags to the pole or the full-range speaker system, strong winds may cause the speaker to blow over. If there is a possibility of windy conditions, then it may be prudent to consider weighting or locking down the Sub to prevent the SP® 218P Sub speaker system from being blown over.

## Operation

---

### **Connecting a Signal to the SP® 218P Sub**

There are a variety of ways to input a signal to the SP® 218P Sub.

The inputs (5) provides either a balanced mic- or line-level input, allowing the use of a 1/4" TRS (ring-tip-sleeve) type phone plug or a male XLR plug.

There is also a 3.5 mm MEDIA IN jack on the Channel 2 input.

The 3.5mm TRS input jack has its own preamp designed for connection to the headphone jack on mobile audio devices. The Channel 2 Gain control adjusts the signal level from all of the channel 2 input connectors. It is possible to use both the combo mic or line input and the 3.5mm input by setting the channel 2 Gain control for the combo input source, and then using the mobile devices headphone volume to adjust its volume.

Note that the 3.5 mm jack mixes a stereo signal down to monophonic, as the SP® 218P Sub is a single sound source.

Do not connect cables to the jacks while the unit is ON and the Gain knob is turned up! While a standard shielded single-ended 1/4" phone plug-equipped cable will work well and the balanced input circuitry will provide some interference rejection, a balanced cable using either the balanced TRS 1/4" phone plug or the XLR plug will provide superior interference rejection and performance.

Sometimes, with difficult interference problems, it will be helpful to lift the shield ground ( Pin #1 of an XLR) of a balanced cable at the SP® 218P Sub end. Check any input changes carefully, always turning the Gain control



down before plugging and unplugging cables, or lifting the ground.

Use of high quality, premium input cables is recommended for the SP® 218P Sub, as these usually have better shielding and materials and will provide greater long-term reliability. The best option is a shielded balanced cable no longer than necessary to reach the SP® 218P Sub. It is usually a good idea to leave some slack at the input to the SP® 218P Sub and also to tape the cables down or run them under a cable guard to avoid anyone tripping over them or pulling the SP® 218P Sub over when a speaker is mounted on the pole.

### **Gain Control Adjustment**

The SP® 218P Sub is equipped with Gain controls (6) on the input to facilitate use in many different applications. With the Gain control adjusted fully clockwise, gain is at maximum and the input sensitivity is 0.42 V RMS for full-rated output with the line level position of the Mic/Line switch (7). When driving the SP® 218P Sub from a mixer, it may be advantageous to reduce the input sensitivity by turning the Gain control to the halfway point. The SP® 218P Sub will now more closely match a typical power amp.

If the mixing board indicates clipping of its output signals, then all of the SP® 218P Sub's power capability is not being utilized cleanly. Clipping the signal before it gets to the SP® 218P Sub is not optimal. Reduce the mixer output level and turn up the Gain control/s on the SP® 218P Sub.

The amplifier in the SP® 218P Sub is equipped with DDT™ and when the DDT™ compression system engages, there is an indication

on the rear panel LCD display (12) that reads “DDT” whenever the DDT™ system engages.

If the sound seems heavily compressed, check the LCD display for this indication, if it is blinking regularly, then the drive level from the mixer (or the Gain control on the SP® 218P Sub) needs to be reduced.

When first turning on the sound system, switch on all upstream electronics first, then the SP® 218P Sub with its Gain control fully counterclockwise (all the way down). Begin checking levels with the mixer output level controls all the way down, and bring them up slowly with the SP® 218P Sub Gain control/s set to the desired setting (one-third way up recommended to start).

It is not good practice to turn the Gain control/s on the SP® 218P Sub all the way up and then try to control level only from the mixer, this approach would tend to pick up excess noise. Best practice would be to run a “hot” signal from the mixer down the cable to the SP® 218P Sub, and then turn the SP® 218P Sub Gain control (6) up only as much as necessary to reach full desired output. With this approach, it is necessary to verify the mixer output is not clipping.

### **Setting the Levels Between the SP® 218P Sub and an SP® 2P Full-Range Speaker System**

The ideal location for placement of the SP® 2P full-range speakers is on top of the SP® 218P Sub pole. In that close proximity, the following settings will provide the best results in the crossover region, and for tonal balance.

In order to set the levels of the subwoofer and the satellite full-range speaker to each other, you first set the SP® 218P Sub gain control (6) to the straight up detent position. Then the SP® 2P gain knob should be set to the following position for the following gain relationship:

12 o'clock face position (straight-up): Sub is hot by approx. 6 dB, above the nominal level of the SP® 2P.

1 o'clock face position (first dot to the right): Sub is a little hot by approx. 3 dB, above the nominal level of the SP® 2P.

2 o'clock face position (second dot to the right): Flat setting, SP® 218 and SP® 2P equal output levels.

This setting will provide the most natural reproduction of vocals and acoustic instruments, when the EQ Presets are set to Flat

To adjust the overall level of both the Sub and the satellite, use the SP® 218P Sub gain knob (6) to adjust the overall levels. Whatever relative levels exist between the Sub and the satellite speaker, will be maintained as the overall levels go up or come down with the Sub gain knob..

If the SP® 2P is located in a different position than on top of the SP® 218P Sub pole, then the polarity of the SP® 2P may need to be changed for best results at the crossover region.

### **Setting the Levels Between the SP® 218P Sub and an SP® 4P Full-Range Speaker System**

In order to set the levels of the subwoofer and the satellite full-range speaker to each other, you first set the SP® 218P Sub gain control (6) to the straight up detent position. Then the SP® 4P gain knob should be set to the following position for the following gain relationship:

11 o'clock face position (first dot to the left): Sub is hot by approx. 6 dB, above the nominal level of the SP® 4P.

12 o'clock face position (straight up): Sub is a little hot by approx. 3 dB, above the nominal level of the SP® 4P.

1 o'clock face position (first dot to the right): Flat setting, SP® 218P Sub and SP® 4P equal output levels.

This setting will provide the most natural reproduction of vocals and acoustic instruments, when the EQ Presets are set to Flat.

These settings are for the SP® 4P set right next to the SP® 218P Sub, in the same plane as the Sub.

### **Setting the SP® 218P Sub Controls for Use with Other Satellite Speakers**

As per the above section, overall level is set by the SP® 218P Sub gain knob (6), and relative gain is set by the satellite speaker's gain or level knob.

For other speakers, several other adjustments may need to be made. Speakers other than the SP® 2P/4P may need a polarity reversal to be made, preferably at the satellite speaker, rather than at the Sub. The satellite speaker polarity should be tried both ways to assure the best performance in the crossover region. The high pass crossover frequency can be adjusted between three choices:

100 Hz, 110 Hz, and 120 Hz.

Note that using the lowest frequency crossover point (100Hz) does not often make for the best results, in fact, use of the 120 Hz setting is recommended in general over the other two choices, for best results overall.

### **Cables from the High Pass Processed Outputs (11)**

The preferred method of connecting a full-range satellite speaker system to the SP® 218P Sub's High Pass Outputs (11), is to use a balanced XLR cable no longer than necessary to comfortably reach the satellite speaker system.

If the satellite speaker is on top of a pole above the SP® 218P Sub, then a 6 foot cable will be plenty long. A 10, or 20 foot cable could also be used, but cables longer than that will only allow more interference pickup, and start to lose high frequency information. Use of high quality, premium cables is recommended for the SP® 218P Sub, as these usually have better shielding and materials and will provide greater long-term reliability. It is usually a good idea to leave some slack at the output of the SP® 218P Sub, and also to tape the cables down or run them under a cable guard to avoid anyone tripping over them or pulling the SP® 218P Sub over when it is holding a speaker on top of it's pole.

**Disconnecting AC Power to the SP® 218P Sub**

We recommend that the Power switch (1) be used to turn the unit off first, and then the AC power cord can be removed, this minimizes stress to the power amplifiers and the transducers from turn-off transients. The power switch has an arc suppression capacitor to help during turn-off, and tends to make a clean disconnect from the AC power, while the power cord IEC connector can make intermittent contact before finally becoming fully disconnected, e.g., as when wiggling the cord.

### SP® 218P Sub DSP User Control Menu Operation

A two-line, 16-character per line LCD and a rotary push-to-select encoder make up the interface for this product.

The DSP processing control accessible by the user, consists of a 9-band graphic equalizer (GEQ), choice of output Polarity, selection of Bass Enhancement, and signal Delay. This is applied to the powered speaker system, and in some cases, to the processed output. The user can also select from a menu of preset Program EQ settings that are applied to the graphic equalizer and Bass Enhancer.

#### User interface:

Rotating the encoder takes the user thru the top level menu screens. These screens will display current information such as a Input Level meter, configuration and current user settings. Pressing the encoder on a top level screen will take the user to related selection screen(s) when relevant. The configuration screens play an important role in preparing the speakers for the intended application. The configuration screen comes up after the initialization screen when the speaker is powered on. If the configuration screen is not selected within 5 minutes the Input Level screen is displayed. The user can still select this screen at any time by rotating the edit knob. The configuration screens help the user set up the SP® 218P Sub system for optimal operation. By answering a couple of questions, the processor is configured and proper connections displayed. When complete, the user is returned to the main menu.

The LCD backlight will dim after 5-minutes without interface activity but returns to full brightness when the encoder is moved. When the backlight auto-dims, the display returns to the Input Level screen. This prevents inadvertent changes from occurring while reactivating the LCD backlight.

The main menu screens are:

- Configure?
- Input Level
- Program EQ (Presets)
- Delay
- Graphic EQ
- Polarity
- Power amp Temperature
- Front LED On/Off
- Auto power Off
- Security Lock

#### Main Screens:

**Input Level meter:** Displays current input signal level.  
Will prominently display status if DDT is engaged, by displaying the letters “DDT” on the right hand side of the display.

#### Configure?

**Push Select** This is an overview display that is not directly edited.  
Entering the configuration menu directs the user how to properly set up and connect the system.

First Screen displayed after pushing **Configure**?

Crossover Sub to  
Proc. Out:110 Hz

Rotate knob to select a different crossover frequency  
110 Hz is the default selection, other choices are 100 Hz and 120 Hz.

Once selection made and the knob is pushed, next screen:

Connect Mixer to:  
Sub input.

Push knob, next screen:

Sub Proc. Out to  
Satellite Spkr

Push knob to go back to the main menu.

With the mixer output (sound source) connected to the subwoofer, all of the system adjustments will be made using the SP Sub DSP module. The User processing choices as in the SP® 2P/4P, such as the 9 band GEQ, will not be used, the SP® 2P/4P should be in Flat mode.

The hi-pass filter on the SP® 2P/4P is unchanged from it's full range setting, because the Sub performs the cross-over functions.

**Program EQ:** Displays current EQ selection (EDM preset is the default on 1st time power up)

(Presets) EDM, Voice, Rock, DJ .....

The program EQ selection is applied to the Graphic Equalizer and Bass enhancer.

“Custom” is displayed if GEQ has been adjusted by the user.

The last preset used, including a Custom one, is what will load the next time the SP® Sub is powered up.

**Delay:** Current delay time

Adjust screen 0 to 150 msec also Feet and Meters

**Graphic EQ:** Current settings 9 Bands +/- 12 dB at ISO octave centers (63Hz to 16 kHz)

Press the encoder to enter the screen to adjust the GEQ. Turning the encoder selects the frequency band to be adjusted. Press the encoder to adjust that band. Pressing the encoder again returns to the band select mode. To exit to the main menu, turn the encoder past the 16 kHz band to the X and Exit will appear. Press the encoder to exit.

**Sub Polarity:**

Normal (Default Selection)

Inverted

**Temperature:** The temperature of the amplifier is monitored and display as long as it is in a safe operating range. If the temperature gets too high, it goes into protect mode which is displayed here and on the main Input Level screen.



**Front LED:** Set front baffle LED operation to:

**On:** When power on indication is selected, the LED is lit blue whenever the amplifiers are not shut down

**Signal:** When signal on indication is selected, the LED is lit blue whenever a signal is present at the input.

**Off:** The LED is turned off for all conditions..

**Auto power off:** Disable, 15, 30 or 60 minute delay.

**Security Lock:** A four digit security lock that can be engaged that will block editing of all parameters. If locked, entry of the access code will be required to allow temporary access for editing. It will automatically relock after 5 minutes of editing inactivity.

### **ALTERNATE METHOD OF CONNECTING A SATELLITE SPEAKER TO THE SUB**

Instead of using the EQ presets in the Sub and feeding an equalized signal to the satellite speaker, and leaving the satellite speaker in a flat mode, the following settings could be used instead.

The signal source (mixer, etc.) will still connect to the SP® 218P Sub first, then a cable from the High-Pass Processed output jack would be connected to the satellite speaker input.

Then set the SP® 218P Sub for a Flat Preset, and use the Presets/EQ/Tone Controls on the satellite speaker to shape its response and behavior.

This would mean not following the Set-up Wizard's instructions for the SP® 2P, but it would provide a little more flexibility of satellite speaker EQ, and allow the SP® 218P Sub response to be unaltered in its frequency response, and then use the relative level of the Sub as the means of tonal balance adjustment. Turn the satellite speaker gain or volume control down to increase the SP® 218P Sub's apparent output level, and then turn the Sub's gain control up to get the overall gain back. To decrease the SP® 218P Sub's apparent output level, turn the satellite speakers gain or volume control up, and turn the SP® 218P Sub gain control down to get back to the overall level point.

### **No Output at All**

First, make sure the unit has AC power and is turned ON. Make sure the LCD screen on the power amp module is illuminated.

If not, make certain the ON/OFF switch (1) is in the ON position and check the IEC power cord connection (3) by ensuring it is fully engaged and seated. Make certain the AC line cord is plugged into a working AC outlet. Finally, check the fuse (2). (See the Rear Panel: FUSE section, for safety instructions.)

Once assured your unit is getting AC power, check that the SP® 218P Sub is getting a signal. Temporarily disconnect the cable running to its inputs and connect it to some other device capable of reproducing the signal (i.e., a power amp and speaker). If this produces a signal, make sure that all Level controls being used have been turned up to a satisfactory level (one-third to halfway).

If the SP® 218P Sub has been subjected to direct sunlight or excessive heat, the built-in thermal protection may have been triggered. If so, turn off the SP® 218P Sub and let it cool for a sufficient amount of time.

If there is still no output, contact your authorized Peavey dealer or the Peavey International Service Center.

### **Hum or Buzz**

If the SP® 218P Sub is producing a hum or buzz, this can be AC outlet related. Try plugging the SP® 218P Sub into a different AC outlet. Sometimes, if a different circuit (breaker) is used for the mixer and for the SP® 218P Sub, it can cause hum problems. Unless it is not practical, it is best to use the same wall outlet (breaker) to supply power to both the mixer and the powered speaker.

Ensure that shielded cables have been used to route the signal to the SP® 218P Sub input. If speaker cables with 1/4" plugs are used as input cables instead of shielded cables, they will be prone to hum or buzz.

Hum may be ground loop related. It may be helpful to lift the shield ground (Pin #1) on a balanced cable at the SP® 218P Sub end. Check any input changes carefully by first turning down the Level control, before plugging and unplugging cables, or lifting the shield ground at the speaker end.

Check to make sure light dimmers are not on the same circuit as the SP® 218P Sub, the mixer or any source devices. If light dimmers are used, then it may be necessary to turn them full ON or full OFF to eliminate or reduce hum. This is a typical AC wiring/light dimmer interference problem, not a design flaw of the SP® 218P Sub.

The third wire (ground plug) on the AC plug should NEVER be removed or broken off, as this is a potential safety hazard.

### **Distorted or Fuzzy Sound**

First, ensure the mixer (signal source) is not clipping or being overdriven. Make sure the Gain (6) control on the SP® 218P Sub has not been set too low. Check that the input plug is fully seated in the input jack on the rear panel of the SP® 218P Sub. Ensure that a power amp has not been plugged into the input jack of the SP® 218P Sub. If an extension cord is being used to provide the AC power to the unit, insure that it is of sufficient current capacity and that it is not also being used to supply power to any other device.

The SP® 218P Sub has built-in EQ to smooth and extend the natural response of the speakers. If excessive additional bass boost have been added externally to the SP® 218P Sub, it could cause premature overload at high SPL.

Reduce the amount of any external (mixer, rack) EQ and see if that clears up the distortion.

If no external bass boost has been added, but there seems to be an excessive amount of bass boost (boominess, bass clipping), then you may want to try a different EQ Preset on the full-range satellite speaker used with the SP® 218P Sub, try the Flat or Acoustic or Country Preset. Using Presets with a lot of bass boost on the full-range satellite speaker can cause the sound to become boomy.

Setting the level of the full-range satellite speaker too low will also tend to cause a boomy sounding bass or mid-bass.

Finally, realize that even though the SP® 218P Sub is a powerful and high output unit, it does ultimately have limits, and it may need additional powered Sub units to provide enough low frequency sound output. In this case, try turning the mixer levels down a little to see if that clears things up. If, after checking all the things listed to check and anything else you can think of to check safely, and the system still exhibits problems, carefully note all conditions and check with your Peavey dealer for advice.

### **Care and Maintenance**

Your SP® 218P Sub is a sturdy and durable product and will provide years of reliable use if properly cared for. Use common sense and read the safety warnings to avoid hazardous operating conditions.

The unit must be disconnected from the AC power source before any work is done on it. Refer all servicing to qualified service personnel.

### **Sunlight/Heat**

Avoid prolonged exposure to direct sunlight, as this may cause the unit to overheat and thermally shut off.

Excessively hot operating conditions can also cause a thermal shutdown.

Do not store in extremely hot or cold conditions or extremely high humidity. Always allow unit to come to room temperature before use.

### **Cleaning**

Never clean the SP® 218P Sub while plugged in or turned ON! When the unit has been fully disconnected from AC power sources, use a dry cloth to remove soil or other dirt. Never use strong solvents on the SP® 218P Sub, as they could damage the cabinet. Do not allow ANY fluids to drip inside the SP® 218P Sub.

### **Touch-Up**

To touch up the painted surfaces of the SP®218P, you can use Peavey® Black Touch-Up paint (part # 00052110). Never paint the enclosure or other parts while the unit is plugged in or turned on!

### **Check for Secure Hardware**

The unit is subject to a great deal of vibration, and this could cause the hardware to loosen with use. After the first few weeks of use and periodically thereafter, check the hardware of the SP® 218P Sub for tightness, including the power amplifier rear panel screws, the grille screws, and other external hardware. Hardware should be firmly tight, but do not over-tighten, as this could strip out the screw or bolt anchor.

### **Architectural and Engineering Specifications**

The powered loudspeaker system shall have a frequency response from 40 Hz to 140 Hz. The peak SPL with inaudible distortion shall reach 131 dB with music as a source, when measured at a distance of 1M and driven to full output capacity. The system shall utilize two 18" Peavey® Pro Rider™. woofer in a vented enclosure tuned to 41 Hz.

The powered loudspeaker system shall have two mixed input channels consisting of a medium impedance input connector consisting of one combo female XLR and 1/4" TRS phone jack on the rear panel. Channel two shall

have a 3.5 mm input jack as well.

There shall be a Direct Thru (output) connector consisting of a male XLR jack.

The output of this jack shall be switchable between just Ch. 1 input and a Mix of Ch 1 and Ch 2. There shall be a filtered high-pass output providing a crossed over signal to a satellite speaker.

The system power amplifiers shall have an unfiltered frequency response of 20 Hz to 20 kHz which deviates no more than +1, -3 dB up to rated power, hum and noise better than 90 dB below rated power, and THD and IMD typically of less than 0.1%.

The woofer amplifiers shall be capable of 500W continuous into each 4 ohm nominal woofer load, and 1,000W peak available power, and incorporate signal compression and limiting.

The input signal shall be electronically divided into high frequencies and low frequencies by a Linkwitz-Riley fourth order slope line-level crossover, with crossover frequencies user selectable from 100 Hz, 110 Hz or 120 Hz. The low frequencies shall be processed to provide bass boost, subsonic filtering and overall response shaping, and the high frequencies shall be made available either flat or equalized for response-shaping via user selectable EQ presets.

The enclosure shall be constructed of 18 mm birch plywood with a textured black polyurethane coating. A pair of metal handles shall be incorporated on the sides of the cabinet, and four sturdy rubber feet for floor standing use. A top rear corner handle and a set of tilt-back casters shall be incorporated for rolling transport on smooth level surfaces.

A full-length powder-coated metal grille shall be provided for woofer protection. The cabinet shall incorporate a threaded pole mount for a pole to be used for a satellite speaker, and the threaded pole shall be included.

The outside dimensions shall be: 47.27" (120.1 cm) tall x 21.13" (53.7 cm) wide x 26.81" (68.1 cm) deep, and the weight shall be 151 lbs. Power requirements shall be: 200 Watts nominal, 120 VAC, 50/60 Hz Domestic and 220-240 VAC, 50/60 Hz (Export). The loudspeaker system shall be called a Peavey® SP® 218P Sub.

## Product Specifications

---

### SPECIFICATIONS

Enclosure: Peavey® SP® 218P Sub

Frequency Response, 1 meter on-axis, swept-sine in anechoic Environment (-6 dB):  
40 Hz – 140 Hz

Usable low frequency limit (-10 dB point): 38 Hz

Power Amp Rating, Total Power Output:  
2,000 watts peak available power  
Continuous Power: 1000 watts cont.

Sound Pressure Level, 1 Watt, 1 meter in anechoic environment:  
97 dB SPL

Maximum Sound Pressure Level (1 meter):  
128 dB SPL continuous  
131 dB SPL peak

Transducer Complement:  
Two 18" Peavey® 1808-4 ALCP Pro Rider™ woofer, 4" voice coil

Box Tuning Frequency:  
41 Hz

Input Connections:  
Two combo female XLR/ 1/4" phone jack providing balanced or unbalanced operation, and one 3.5 mm stereo media jack.

Output Connections:  
Two XLR Outputs, one Full Range Thru, electrically buffered with selectable option of Channel 1 input only, or Ch. 1 and Ch. 2 mixed. One High -Pass Output

Controls:  
Ch. 1 and Ch. 2 Gain control knob  
Ch. 1 and Ch. 2 Mic/Line gain select pushbutton

Electronic Crossover:  
DSP based, with LCD display and Rotary Encoder Knob for selection of crossover and EQ presets.  
Crossover Frequency Set to 110 Hz  
Low Pass slope: 24 dB/octave  
High Pass Output slope: 24 dB/octave

Infrasonic Filter Slope:  
36 dB/octave



#### Enclosure Materials & Finish:

Textured black polyurethane painted enclosure with 18 mm Baltic Birch plywood, with a full-length, black powder coated perforated steel grille.

#### Dimensions (H x W x D)

47.27 in. x 21.13 in. x 26.81 in.

1201 mm x 537 mm x 681 mm

#### Net Weight:

151 Lbs. (68.6 kg)

#### Mounting Provisions:

1 3/8" pole mount with M20 threaded pole for stand mounting a suitable speaker on top of the Sub, and four large rubber feet on bottom for floor use.

#### **ELECTRONICS AND AMPLIFIER SPECIFICATIONS:**

##### Electronic input impedance (nominal):

Balanced inputs: 10 k ohms line level sensitivity selected.

Unbalanced input: 5 k ohms, line level sensitivity selected.

Mic switch sensitivity Increase: 26 dB

Input Sensitivity for Full Output (Level full CW): 0.42V RMS  
(Switch in LINE position)

Input Overload Point (Switch in LINE position): +14 dBV

Status Indicators: Front baffle LED is blue for power ON indication, or can be turned Off, or set to turn On only when signal is present.

Rear panel LCD screen in Input Level mode, shows DDT activation by flashing "DDT" on the LCD screen, right hand side. Signal level indicated by bar graph coming from left hand side of LCD.

##### DSP Section Specifications:

Latency: Approx. 2.7 msec

ADC and DAC Sampling frequency: 96 kHz

Bit Depth: 24 bits for ADC/DAC, 32 bits for DSP calculations.

Infrasonic filter protection: 36 dB/octave roll-off

Nominal amplifier frequency response: +0, -1 dB from 10 Hz to 30 kHz

Hum and noise: Greater than 90 dB below rated power

DDT dynamic range: Greater than 14 dB

THD and IM: Typically less than 0.1 %

Damping factor: Greater than 50 @ 1000 Hz, 4 ohms

Power requirements of Peavey® SP® 218P Sub system (domestic):  
Nominal 200 watts, 120 VAC, 60 Hz

### Fuse Type

For 120 VAC USE: International fuse classification T10AH 250V. In the USA, types GDC, GMC, 215, 218, and 477 cartridge-style 5 x 20 mm size time-delay fuses with a 10 amp 250V rating can be used.

For 220-240VAC USE: International fuse classification T5AH 250V . This is a cartridge style 5 x 20 mm size time-delay fuse with a 5 amp 250V rating.

**Specifications subject to change without notice.**

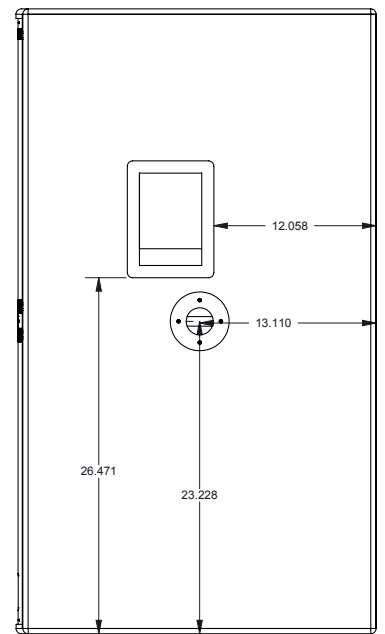
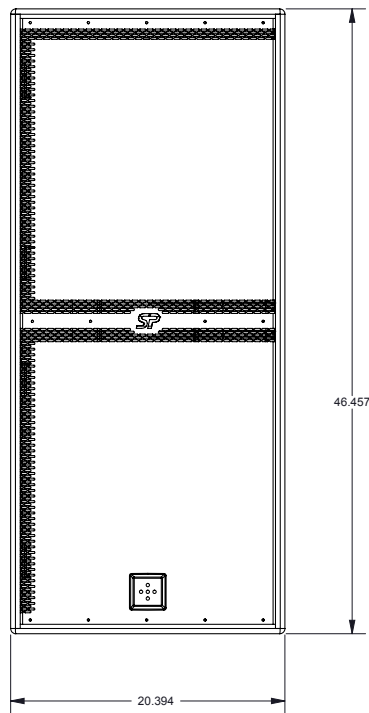
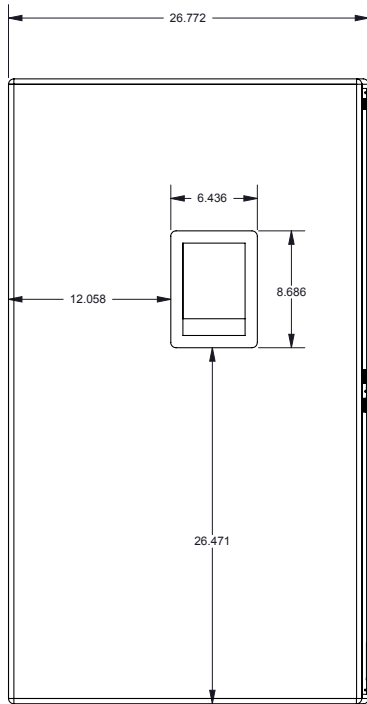
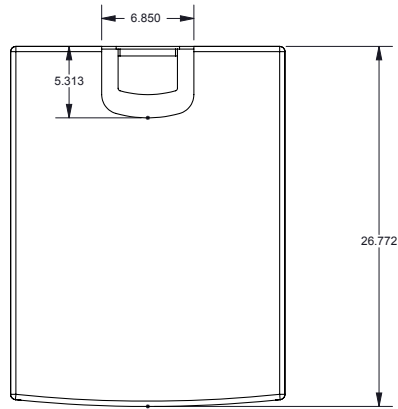

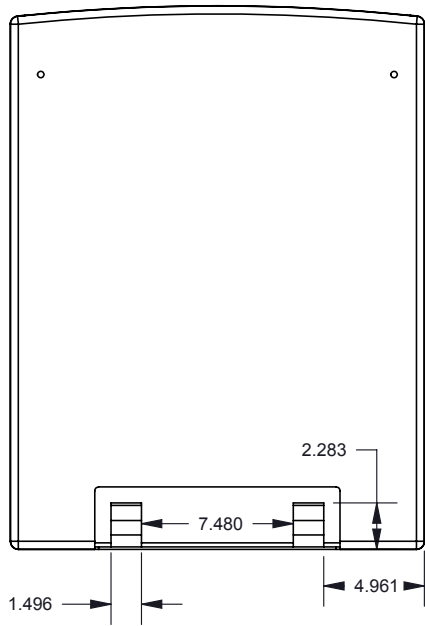
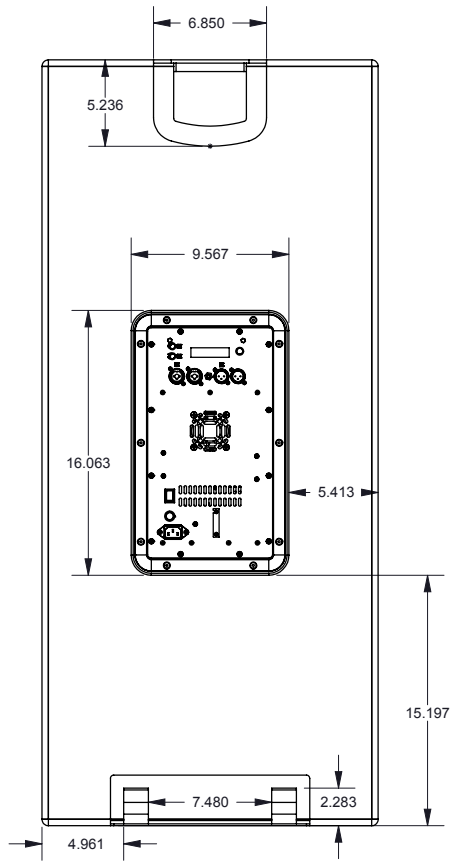



[www.peavey.com](http://www.peavey.com)

Warranty registration and information for U.S. customers available online at  
[www.peavey.com/warranty](http://www.peavey.com/warranty)  
or use the QR tag below



Features and specifications subject to change without notice.

Peavey Electronics Corporation 5022 Hartley Peavey Drive Meridian, MS 39305 (601) 483-5365 FAX (601) 486-1278



Logo referenced in Directive 2002/96/EC Annex IV  
(OJ(L)37/38, 13.02.03 and defined in EN 50419: 2005  
The bar is the symbol for marking of new waste and  
is applied only to equipment manufactured after  
13 August 2005