

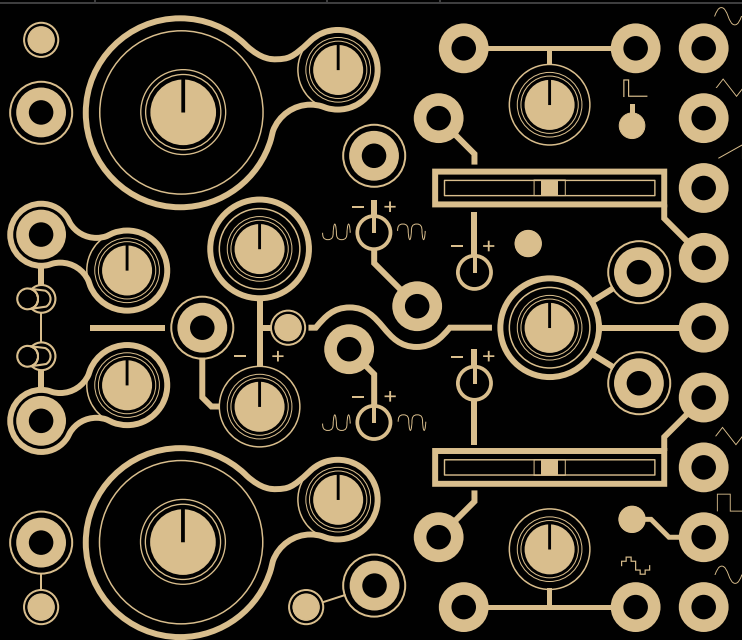

INSTRUO | SPECIALIST
SYNTHESIZERS



CŠ-L
Complex Oscillator
User Manual

Contents

3	Description / Features	14	Frequency Modulation
4	Installation / Specifications	15	Wavefolding
5	Overview	17	Oscillator Synchronisation
7	Oscillators	19	Amplitude Modulation
12	Frequency/Pitch	21	Internal Modulation Routing
13	Link Button	26	Patch Examples

Description

The Instruō **Cš-L** is a dual analogue oscillator optimised for generation of complex waveforms. It features two contrasting discrete circuit oscillators that are normalised to one another, offering a variety of simultaneous modulation routings. The resulting harmonic timbres sit far beyond the realms of traditional subtractive synthesis.

It expands upon the classic complex oscillator paradigm prominent in the West Coast synthesis philosophy. Typical cross modulation is expanded upon with inclusion of signal multiplication/amplitude modulation, a wavefolder per oscillator, final waveform symmetry biasing, classic and contemporary PWM, a global modulation index bus, and a digitally-controlled routing scheme that can be configured on-the-fly.

With the two separate oscillator cores, simultaneous access to all included waveforms, and the ability for bi-directional modulation, the **Cš-L** truly allows the user to shape sound like never before.

Features

- Two independent contrasting cored analogue oscillators
- Wavefolder per oscillator
- Waveform symmetry biasing
- 1V/Oct linking for parallel tracking
- Four-quadrant signal multiplication/amplitude modulation
- Internal oscillator sync capabilities
- Digitally-controlled internal modulation routing
- Global modulation index bus
- LFO capabilities
- Sub-square modes

Installation

1. Confirm that the Eurorack synthesizer system is powered off.
2. Locate 26 HP of space in your Eurorack synthesizer case.
3. Connect the 10 pin side of the IDC power cable to the 2x5 pin header on the back of the module, confirming that the red stripe on the power cable is connected to -12V.
4. Connect the 16 pin side of the IDC power cable to the 2x8 pin header on your Eurorack power supply, confirming that the red stripe on the power cable is connected to -12V.
5. Mount the Instruō **Cš-L** in your Eurorack synthesizer case.
6. Power your Eurorack synthesizer system on.

Note:

This module has reverse polarity protection.

Inverted installation of the power cable will not damage the module.

Specifications

- Width: 26 HP
- Depth: 35mm
- +12V: 200mA
- -12V: 80mA

CŠ-L | si:əz-əl | proverb (derivative) “complex sauce-later”

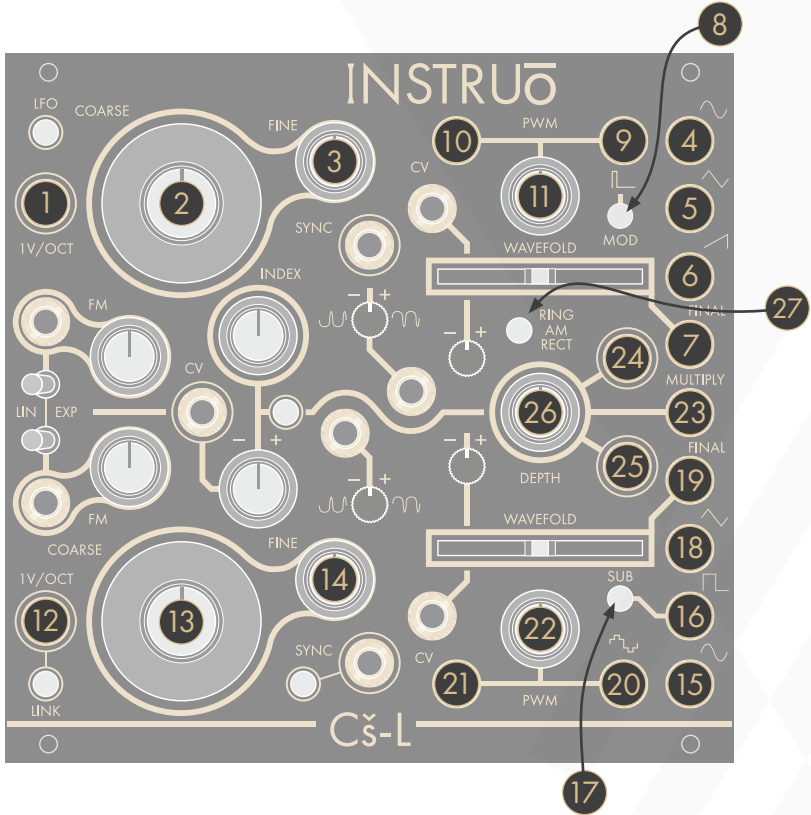

Key —

- | | |
|----------------------------|------------------------------|
| 1. Osc A 1V/Oct Input | 15. Osc B Sine Output |
| 2. Osc A Coarse Frequency | 16. Osc B Square Output |
| 3. Osc A Fine Frequency | 17. Sub Button |
| 4. Osc A Sine Output | 18. Osc B Triangle Output |
| 5. Osc A Triangle Output | 19. Osc B Final Output |
| 6. Osc A Sawtooth Output | 20. Osc B PWM Output |
| 7. Osc A Final Output | 21. Osc B PWM CV Input |
| 8. Mod Button | 22. Osc B PWM |
| 9. Osc A PWM Output | 23. Multiply Output |
| 10. Osc A PWM CV Input | 24. Multiply Modulator Input |
| 11. Osc A PWM | 25. Multiply Carrier Input |
| 12. Osc B 1V/Oct Input | 26. Depth |
| 13. Osc B Coarse Frequency | 27. Ring/AM/Rect Button |
| 14. Osc B Fine Frequency | |

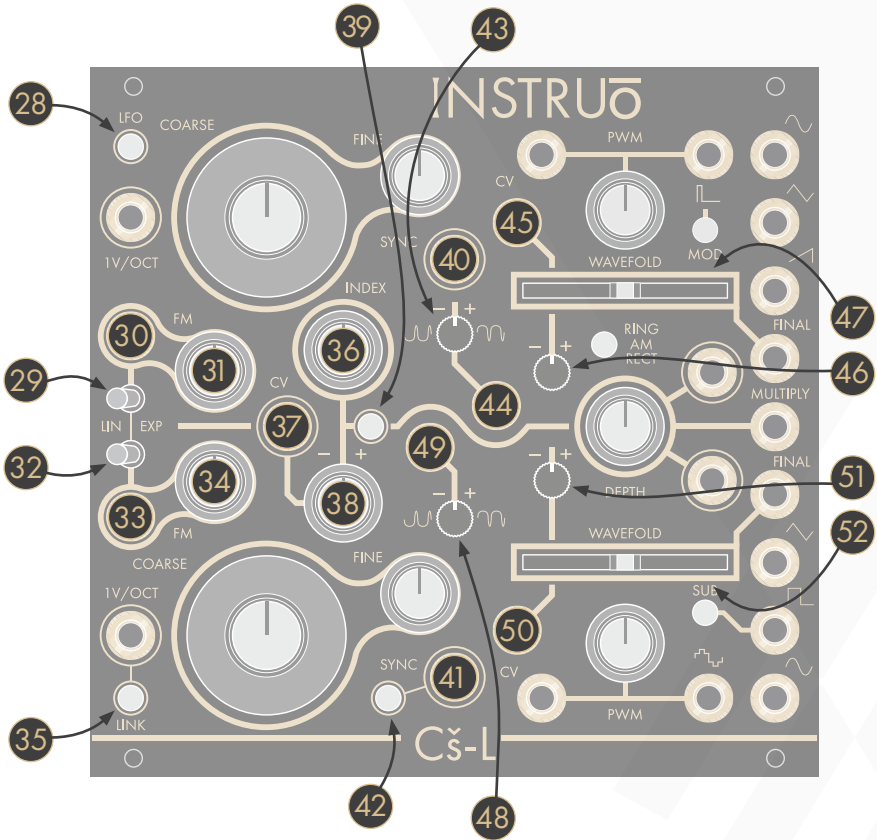

Key

- | | |
|--------------------------|--------------------------------------|
| 28. LFO Button | 41. Soft Sync Input |
| 29. Osc A Lin/Exp Toggle | 42. Sync Button |
| 30. Osc A FM Input | 43. Osc A Symmetry Bias Attenuverter |
| 31. Osc A FM Attenuator | 44. Osc A Symmetry Bias Input |
| 32. Osc B Lin/Exp Toggle | 45. Osc A Wavefold CV Input |
| 33. Osc B FM Input | 46. Osc A Wavefold Annenuverter |
| 34. Osc B FM Attenuator | 47. Osc A Wavefold Fader |
| 35. Link Button | 48. Osc B Symmetry Bias Attenuverter |
| 36. Index Knob | 49. Osc B Symmetry Bias Input |
| 37. Index CV Input | 50. Osc B Wavefold CV Input |
| 38. Index Attenuverter | 51. Osc B Wavefold Annenuverter |
| 39. Index Button | 52. Osc B Wavefold Fader |
| 40. Hard Sync Input | |

Oscillators

Oscillators A and B share various similarities, but they utilise very different circuitry architectures. **Oscillator A** features a **sawtooth core** circuit while **Oscillator B** features a **triangle core** circuit. This contrast in cores result in slight variations in the harmonic content of each oscillators' available waveforms and their strengths and weaknesses. In short, sawtooth core circuits can do certain things better than triangle core circuits, and vice versa. The **Cš-L** offers the best of both worlds

It is important to note that, because of their different architectures and configurations, each oscillator has a different global frequency range. This means that matching pointer positions on the **Coarse** and **Fine** frequency knobs will not necessarily result in matching output frequencies.

The peak-to-peak amplitude of the various waveform outputs differ from each other slightly. The reference point is 10Vpp on the sawtooth wave. The other signal amplitudes were purposefully chosen to give a more balanced perceived loudness over a musical range. This effect is most prominent between the more harmonically rich waveforms.

Oscillator A (Sawtooth Core)

 **Sine Output:** Sine waveform output.

 **Triangle Output:** Triangle waveform output.

 **Sawtooth Output:** Sawtooth/Ramp waveform output.

Final Output: Final waveform output.

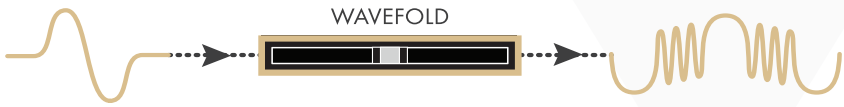

- The waveform is determined by the **Wavefold** parameter and the **Symmetry Bias Attenuverter**.

PWM Output: Pulse width modulation waveform output.

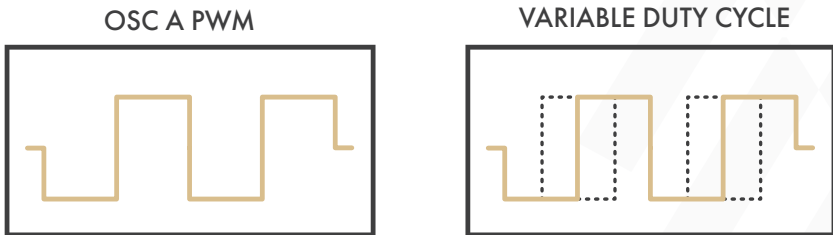

 **PWM:** The **PWM** knob controls the duty cycle ratio of the pulse width modulation waveform.

- Turning the knob clockwise will increase the $+/-$ ratio of the pulse wave.
- Turning the knob anticlockwise will decrease the $+/-$ ratio of the pulse wave.
- The range of the **PWM** knob was chosen to always result in a signal with an audible duty cycle when used without external control voltage.

PWM CV Input: The **PWM CV Input** is a bipolar control voltage input for the **PWM** parameter.

- Control voltage sums with the **PWM** knob position.
- Input range: $-/+5V$.
- Note that with external control voltage extending the controllable range of the duty cycle, audibility of the signal will drop when pushed beyond 0% and 100%.

LFO Button: The **LFO Button** will switch Oscillator A to sub-audio range frequencies.

- If the **LFO Button** is unilluminated, Oscillator A will output audio range frequencies.
- Oscillator A will continue to track $1V/Octave$ when set to **LFO Mode**.
- The LFO will reset with every rising edge signal present at the **Hard Sync Input** of Oscillator A.

☀ If the **LFO Button** is illuminated white, Oscillator A will output sub-audio range frequencies.

LFO Hard Sync

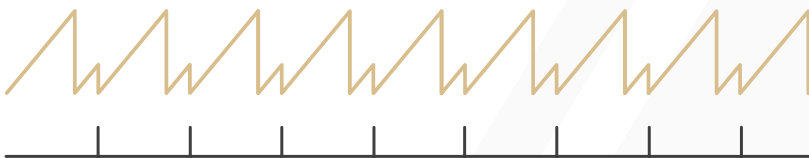

Oscillator B (Triangle Core)

Final Output: Final waveform output.

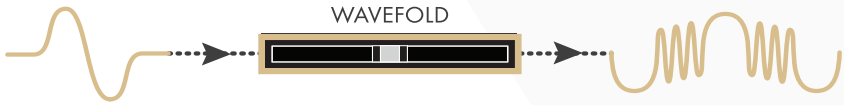

- The waveform is determined by the **Wavefold** parameter and the **Symmetry Bias Attenuverter**.

 **Triangle Output:** Triangle waveform output.

 **Square Output:** Square waveform output.

Sub Button: The **Sub Button** determines the octave of the **Square Output**.

- If the **Sub Button** is unilluminated, the square waveform is set to the fundamental frequency of Oscillator B.

 If the **Sub Button** is illuminated white, the square waveform is set to one octave below the fundamental frequency of Oscillator B.

 If the **Sub Button** is illuminated amber, the square waveform is set to two octaves below the fundamental frequency of Oscillator B.

 **Sine Output:** Sine waveform output.

PWM Output: Stepped triangle waveform output.

OSC B PWM

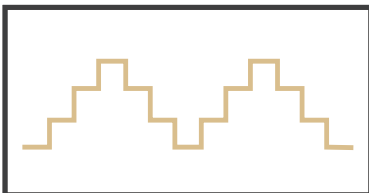

VARIABLE DUTY CYCLE

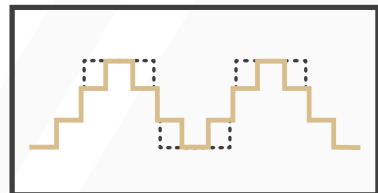

PWM: The **PWM** knob controls the width of the upper and lower pulses of the stepped triangle waveform.

- Turning the knob clockwise will increase the width of the upper and lower pulses.
- Turning the knob anticlockwise will decrease the width of the upper and lower pulses.
- The range of the **PWM** knob was chosen to always result in a signal with an audible duty cycle when used without external control voltage.

PWM CV Input: The **PWM CV Input** is a bipolar control voltage input for the **PWM** parameter.

- Control voltage sums with the **PWM** knob position.
- Input range: $-/+5V$.
- Note that with external control voltage extending the controllable range of the duty cycle, audibility of the signal will drop when pushed beyond 0% and 100%.

Frequency/Pitch

Coarse: The **Coarse** knob controls the fundamental frequency of the oscillator. It determines the pitch of all corresponding waveforms.

- Turning the knob clockwise will increase the frequency.
- Turning the knob anticlockwise will decrease the frequency.

Fine: The **Fine** knob is used for minute control of the oscillator's fundamental frequency and is relative to the frequency value set by the **Coarse** knob. It also determines the pitch of all corresponding waveforms.

- Turning the knob clockwise will increase the frequency.
- Turning the knob anticlockwise will decrease the frequency.

1V/Oct Input: The **1V/Oct Input** is a bipolar control voltage input that is calibrated to 1V per octave.

- This is traditionally used for frequency control (musical pitch) sent from a sequencer or keyboard.
- Control voltage is added to the summed values set by the **Coarse** and **Fine** knobs.

Link Button

The **Link Button** will bidirectionally normal 1V/Octave control voltage signals from one oscillator to the other via either **1V/Oct Input**.

- If the **Link Button** is unilluminated, linking is disabled, and the **1V/Oct Input** will control the corresponding oscillator only.
- ☀ If the **Link Button** is illuminated white, linking is engaged. Sending control voltage to the **1V/Oct Input** of Oscillator A only will control both Oscillators A and B. Similarly, sending control voltage to the **1V/Oct Input** of Oscillator B only will control both Oscillators B and A.
- If a second 1V/Octave signal is patch in either of the above configurations the **Link** routing normal is broken and the oscillators will track independently.

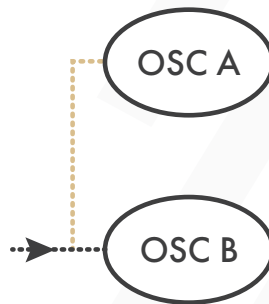
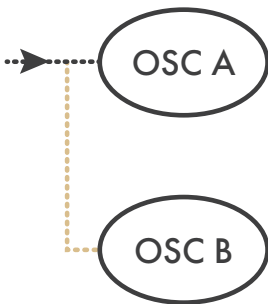

Frequency Modulation

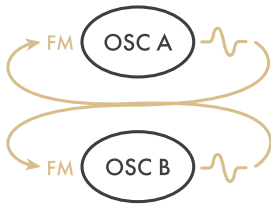

FM Input: The **FM Input** is a bipolar control voltage input for the frequency parameter of the oscillators.

- Control voltage is summed with the values set by the **Coarse** and **Fine** knobs and scaled by the **FM Attenuator**.
- By default, the sine waveform of Oscillator A is normalised to the **FM Input** Oscillator B. Similarly, the sine waveform of Oscillator B is normalised to the **FM Input** Oscillator A.
- An external signal present at the **FM Input** will break the normalised sine waveform connection and act as the modulator.

FM Attenuator: The **FM Attenuator** determines the depth of frequency modulation applied to the corresponding oscillator.

- Turning the knob clockwise will increase the depth of frequency modulation.
- Turning the knob anticlockwise will decrease the depth of frequency modulation.

Lin/Exp Toggle: Each **FM Input** can be individually set to a linear or exponential frequency modulation response curve.

- If the toggle is set to the left position, the FM signal will apply with linear scaling.
- If the toggle is set to the right position, the FM signal will apply with exponential scaling.
- If the toggle is set to exponential FM and the **FM Attenuator** is fully clockwise, the **FM Input** will essentially track $1V/Octave$ (Its tracking may differ slightly from the calibrated $1V/Oct$ Input).

Wavefolding



Wavefold: The **Wavefold** faders control the amount of wavefolding applied to the sine waveform of each respective oscillator. Folded signals are present at the **Final Outputs**. Unlike traditional distortion effects where signal amplitude passing a threshold is 'clipped', wavefolding inverts signal amplitude when it passes a threshold. This folding can occur multiple times resulting in dynamic control over rich harmonic spectra.

- The sine waveforms normal to the **Wavefolders**.
- Moving the fader fully left will reduce the signal's amplitude, resulting in near-silence.
- Moving the fader to the centre results in a waveform that resembles a sine waveform (depending on the position of the **Symmetry Bias Attenuverter**).
- Moving the fader fully right results in a rich, harmonic timbre (Adjusting the **Symmetry Bias Attenuverter** will further affect the harmonic makeup).

Wavefold CV Input: The **Wavefold CV Input** is a bipolar control voltage input for the Wavefold parameter.

- Control voltage is summed with the fader position and scaled by the **Wavefold Attenuverter**.

Wavefold Attenuverter: The **Wavefold Attenuverter** will scale and invert the control voltage signals present at the **Wavefold CV Input**.

Symmetry Bias Attenuverter: The **Symmetry Bias Attenuverter** controls the DC offset amount of the sine waveform normalised to the **Wavefold** input. The amount of DC offset is applied before the wavefolding stage.

- By default, a DC reference voltage is normalised to the signal attenuverter.
- The centre position of this knob is calibrated to 0V.

- Turning the knob anticlockwise applies a negative bias to the normalised sine waveform.
- Turning the knob clockwise applies a positive bias to the normalised sine waveform.
- Applied DC bias will affect the harmonic overtones of the waveform.

Symmetry Bias Input: A signal present at the **Symmetry Bias Input** will replace the normalised reference voltage. The external signal can be scaled and inverted via the **Symmetry Bias Attenuverter**. The incoming signal sums with the normalised sine waveform before reaching the wavefolding stage.

The wavefold circuit can be isolated for processing external signals via the **Symmetry Bias Input**. The **Symmetry Bias Attenuverter** controls the amplitude of the external signal. Decreasing the amount of wavefolding via the **Wavefold** fader will isolate only the external signal at the **Final Output**.

Oscillator Synchronisation

Both oscillators have an external synchronisation input, labeled **Sync** on the front panel.

Hard Sync Input: Oscillator A implements **Hard Synchronisation**.

OSC A HARD SYNC

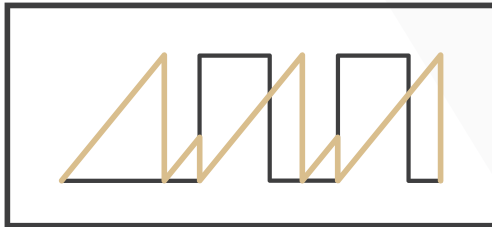

- On a rising edge signal, the oscillator's cycle will reset.
- Hard edged signals such as sawtooth/ramp and square waveforms work best for the **Hard Sync Input** of Oscillator A.
- Voltage threshold: 2.5V.

Soft Sync Input: Oscillator B implements **Soft Synchronisation**.

OSC B SOFT SYNC

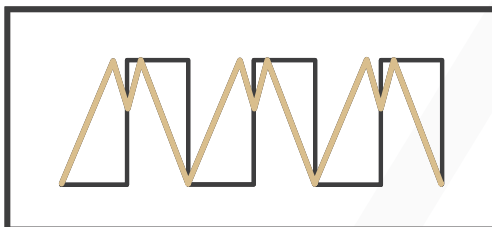

- This is also known as **Frequency Lock** or **X-Lock**.
- The oscillator's core triangle waveform changes its charge direction when clocked.

- When tuning Oscillator B to an external signal, the **Soft Sync Input** can be used to phase lock the signals to remove beat frequencies in unison and perfect interval tunings.
- Oscillator B will lock to integer multiples of the external signal.
- Musical intervals such as perfect octaves, perfect 4ths, and perfect 5ths work best for the **Soft Sync Input** of Oscillator B.
- Voltage threshold: 2V.

Sync Button: The **Sync Button** determines the internal synchronisation routing between the two oscillators.

- When the **Sync Button** is unilluminated, no internal synchronisation is applied.
- ☀ When the **Sync Button** is illuminated amber, the sawtooth/ramp waveform of Oscillator A will normal to the **Soft Sync Input** of Oscillator B, soft synchronising Oscillator B to Oscillator A.
- ☀ When the **Sync Button** is illuminated white, the square waveform of Oscillator B will normal to the **Hard Sync Input** of Oscillator A, hard synchronising Oscillator A to Oscillator B.
- Pressing the **Sub Button** will change the octave of the synchronising signal.

Amplitude Modulation

The module features an on-board signal multiplier which can be utilised as a four-quadrant multiplier, internal/external signal rectifier, and as a traditional voltage controlled amplifier.

Multiply Inputs: Each oscillators' sine waveform is normalised to its corresponding **Multiply Input** jack.

- Signals present at the **Multiply Inputs** will break the normalised sine waveforms and become the sources for signal multiplication.
- Similar to the wavefold circuit, the amplitude modulation circuit can be accessed for use independent of Oscillators A and B.







Multiply Output: Multiplied signal output.

- The timbre is determined by the signals present at the **Multiply Inputs**.

Depth: The **Depth** knob determines the amplitude of the top signal applied to the multiplier circuit. Due to the nature of signal multiplication, this effectively controls the resulting amplitude of the output signal.

- In comparison to the rich timbres produced at the **Final Outputs**, signals produced by the multiplier often appear softer to the ear, even with approximately equal signal amplitudes. Due to this difference in perception, the multiplier has a purposefully increased gain level on its inputs.
- Unity gain of the multiplier can be achieved by setting the pointer of the **Depth** knob to point approximately at the **Multiply Modulator Input** (2 o'clock). Once the knob is past that point, the multiplied signals will clip in a harmonically pleasing way.

Ring/AM/Rect Button: The **Ring/AM/Rect Button** determines the amplitude modulation mode for the **Multiply Modulator Input**.

-  If the button is unilluminated, **Ring Modulation Mode** is selected. This mode functions as a full four-quadrant multiplier which achieves bipolar amplitude modulation. 
-  If the button is illuminated white, **Half Wave Rectification Mode** is selected. This mode omits any negative portion of the signal seen at the **Multiply Input** of Oscillator A, cropping the signal to 0V. 
-  If the button is illuminated amber, **Full Wave Rectification Mode** is selected. This mode inverts any negative portion of the signal seen at the **Multiply Input** of Oscillator A. This input signal becomes unipolar positive. 

Internal Modulation Routing

There are two internal linear VCAs on the Cš-L. The sine waveforms of each oscillator route to these in parallel with the **Sine Outputs**. The amplitudes of these VCAs are controlled simultaneously via the **Index** bus. Each VCA controlled sine waveform can be routed to up to four modulation destinations, each that can be defined independently without patching a single cable.

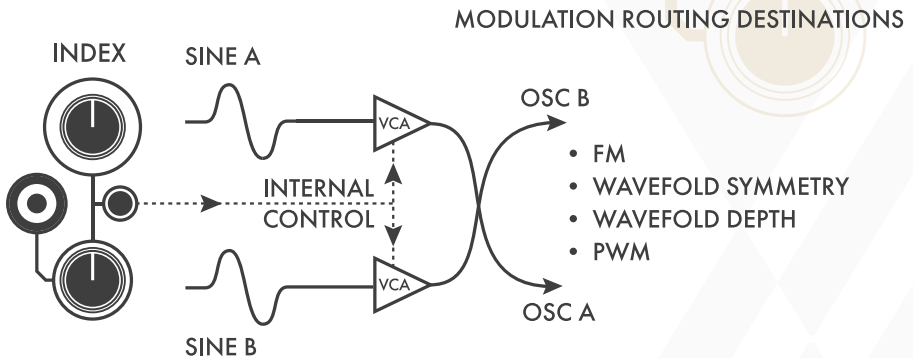

Index: The **Index** knob simultaneously sets the gain level of the two internal VCAs.

- Turning the knob anticlockwise decreases the global depth of modulation.
- Turning the knob clockwise will increase the global depth of modulation.

Index Attenuverter: The **Index Attenuverter** will scale and/or invert the control voltage signals present at the **Index CV Input**.

Index CV Input: The **Index CV Input** is a bipolar control voltage input for the **Index** parameter.

- Control voltage is scaled and/or inverted by the **Index Attenuverter** and summed with the **Index** knob position.

Mod Button: The **Mod Button** is used to set the internal routing of the **Index** signals to the opposite oscillators **PWM CV Input**.

- If the button is unilluminated, internal modulation routing is disabled.
- ☀ If the button is illuminated white, the sine waveform of Oscillator A is routed to the **PWM CV Input** of Oscillator B, and vice versa.
- ☀ If the button is illuminated amber, the sine waveform of Oscillator A is routed to the **PWM CV Input** of Oscillator B only.

Index Button: The **Index Button** functions as a “shift” control. While pressed down, the other 6 buttons can be used to enable and disable internal modulation routings.

- Pressing the **Index Button** will display which routings are enabled and disabled. The buttons are illuminated white when the corresponding modulation routing is enabled and unilluminated when disabled.
- The **Index** controlled sine waveforms are used for the internal modulation (Oscillator A can modulate the parameters of Oscillator B, and vice versa).

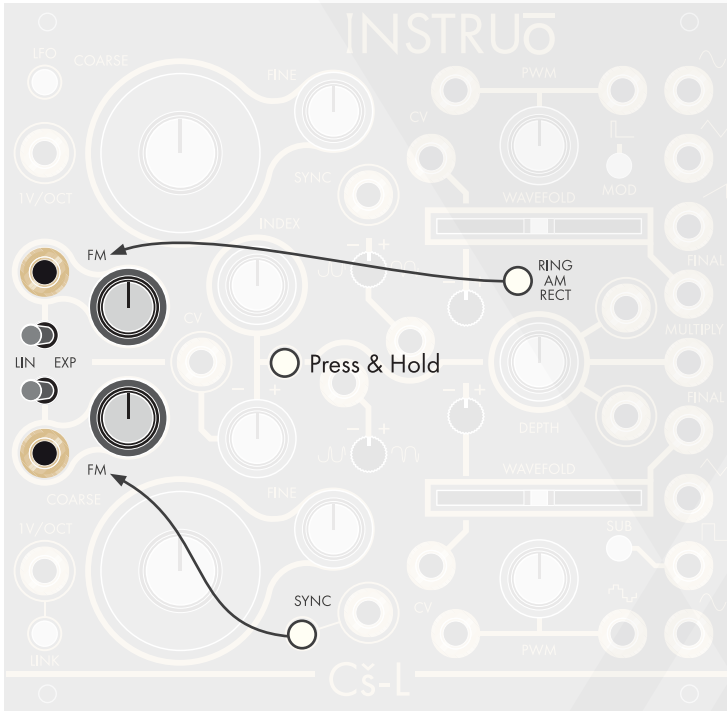

- The internal modulation destinations are as follows:

The **Ring/AM/Rect Button** is used to enable/disable the modulation routing to the **FM Input** of Oscillator A (When disabled, the sine waveform of Oscillator B is directly normalised to this destination and not controlled by the **Index** parameter).

The **Sync Button** is used to enable/disable the modulation routing to the **FM Input** of Oscillator B (When disabled, the sine waveform of Oscillator A is directly normalised to this destination and not controlled by the **Index** parameter.).

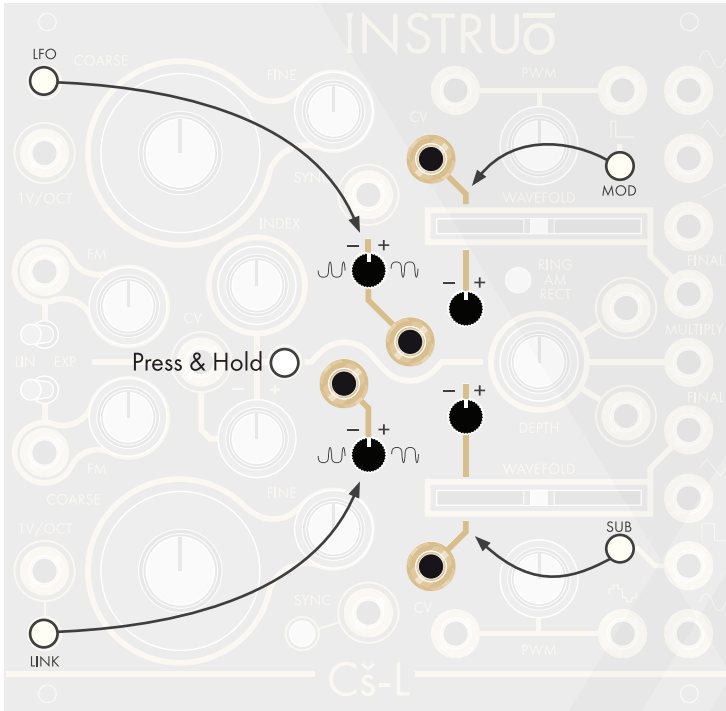

The **Mod Button** is used to enable/disable the modulation routing to the **Wavefold CV Input** of Oscillator A.

The **Sub Button** is used to enable/disable the modulation routing to the **Wavefold CV Input** of Oscillator B.

The **LFO Button** is used to enable/disable the modulation routing to the **Symmetry Bias Input** of Oscillator A.

- It is important to note that when enabled, the modulation signal replaces the default reference voltage. The **Symmetry Bias Attenuverter** will control the inversion and depth of the **Index** modulation signal.

The **Link Button** is used to enable/disable the modulation routing to the **Symmetry Bias Input** of Oscillator B.

- It is important to note that when enabled, the modulation signal replaces the default reference voltage. The **Symmetry Bias Attenuverter** will control the inversion and depth of the **Index** modulation signal.

Patch Examples

East Coast Synth Voice:

Summary: The sequencer or keyboard sends voltages to **Cš-L** while simultaneously triggering the envelope generator. The CV output of the envelope generator opens the filter and VCA, allowing **Cš-L**'s signal to pass through. More traditional East Coast patches would incorporate separate envelope generators for the filter and VCA.

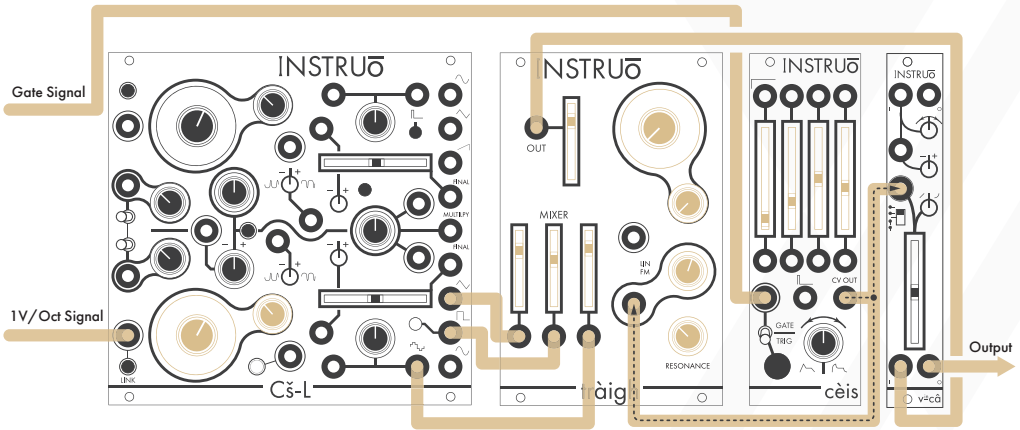

Audio Path:

- Connect the **Square**, **PWM**, and **Triangle** waveforms of Oscillator B to three inputs of a mixer.
- Set the **Sub Button** to illuminate white, dropping the square waveform by 1 octave.
- Connect the output of the mixer to the audio input of a filter.
- Connect the audio output of the filter to the audio input of a VCA.
- Monitor the audio output of the VCA.
- Set the **Coarse** and **Fine** knobs of Oscillator B to desired positions.
- Set the individual levels of the mixer to desired positions.
- Set the cutoff frequency of the filter to a desired position.
- Set the resonance of the filter to a desired position.
- Set the level of the VCA to a desired position.

Control Path:

- Connect the 1V/Oct output of a sequencer or keyboard to the **1V/Oct Input** of Oscillator B.
- Connect the gate output of the sequencer or keyboard to the trigger input of an envelope generator.
- Connect the CV output of the envelope generator to a multiple.
- Connect one copy of the envelope generator CV signal to the CV input of the filter and set the corresponding CV attenuator to a desired position.
- Connect a second copy of the envelope generator CV signal to the CV input of the VCA and set the corresponding CV attenuator to a desired position.
- Set the envelope stages to desired positions.

Complete Synth Voice:

Summary: The sequencer or keyboard sends note voltages to **Cš-L** while simultaneously triggering the envelope generator. The CV output of the envelope generator modulates the wavefolder, allowing for timbral changes. The same envelope generator CV signal modulates the **Multiply Carrier Input** which functions as a VCA. This allows **Cš-L**'s signal to pass through. More traditional synth voice patches would incorporate separate envelope generators for the wavefolder and **Multiply Input**.

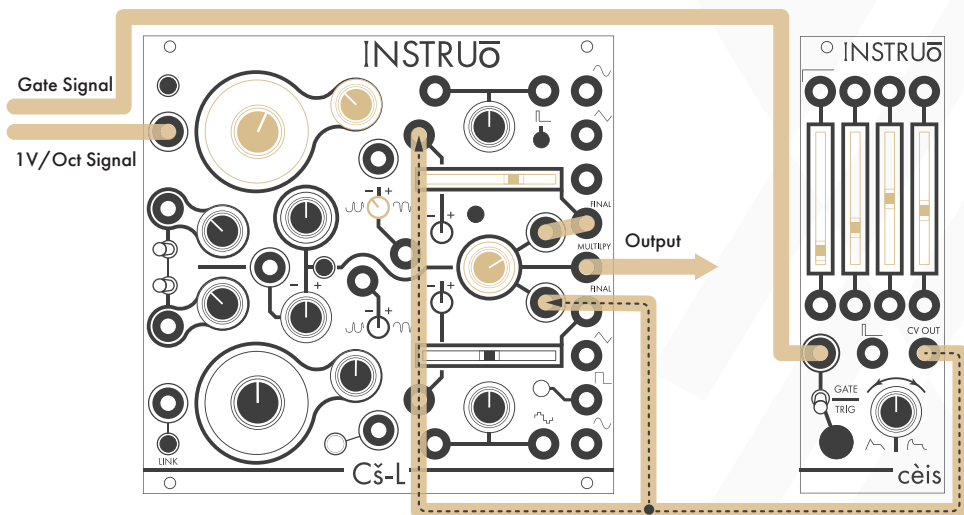

Audio Path:

- Connect the **Final** waveform of Oscillator A to the **Multiply Modulator Input**.
- Set the **Coarse** and **Fine** knobs of Oscillator A to desired positions.
- Set the **Wavefold** fader of Oscillator A to a desired position.
- Set the **Symmetry Bias Attenuverter** of Oscillator A to a desired position.
- Monitor the **Multiply Output**.

Control Path:

- Connect the 1V/Oct output of a sequencer or keyboard to the **1V/Oct Input** of Oscillator A.
- Connect the gate output of the sequencer or keyboard to the trigger input of an envelope generator.
- Connect the CV output of the envelope generator to a multiple.
- Connect one copy of the envelope generator CV signal to the **Wavefold CV Input** of Oscillator A.
- Connect a second copy of the envelope generator CV signal to the **Multiply Carrier Input**.
- Set the **Depth knob** to a desired position.
- Set the envelope stages to a desired position.

Sync'd Growl:

Summary: Both **Final** waveforms are multiplied together through a ring modulator. The sine waveform of Oscillator A modulates the **Wavefold** and **Symmetry Bias** parameters of Oscillator B while the sine waveform of Oscillator B modulates the same parameters of Oscillator A. The depth of internal modulation is set by the **Index** knob. The square waveform of Oscillator B hard synchronises Oscillator A. The sine waveform of Oscillator B frequency modulates Oscillator A. 1V/Octave linking is enabled so that the sequencer or keyboard control voltage signal needs to be present at one **1V/Oct Input** only. The sequencer or keyboard sends voltages to **Cs-L** while simultaneously triggering the envelope generator. The CV output of the envelope generator opens the filter and VCA, allowing **Cs-L**'s signal to pass through. More traditional East Coast patches would incorporate separate envelope generators for the filter and VCA.

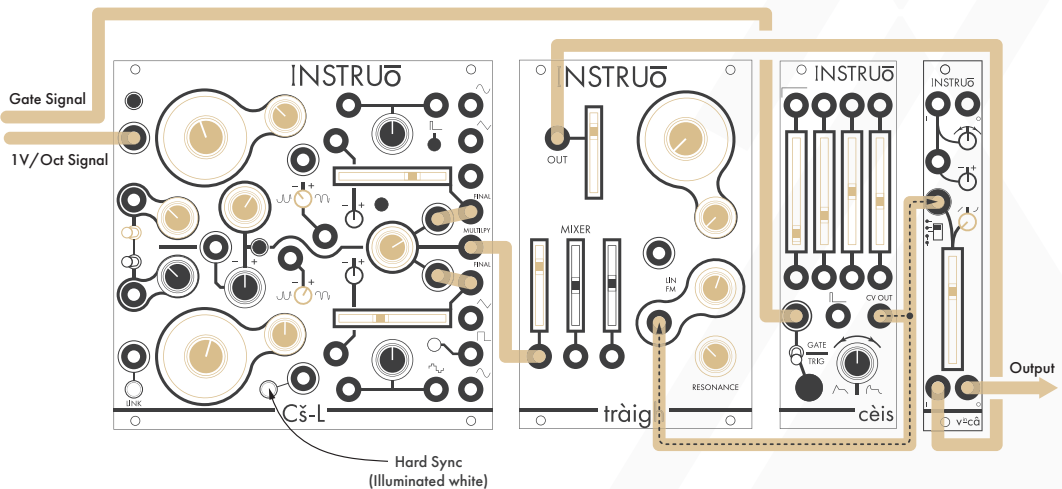

Audio Path:

- Connect both **Final** waveforms of **Cs-L** to the respective **Multiply Inputs**.
- Connect **Multiply Output** to the audio input of a filter.

- Hard synchronise Oscillator A to the square waveform of Oscillator B by setting the **Sync Button** so that it illuminates white.
- Connect the audio output of the filter to the audio input of a VCA.
- Monitor the audio output of the VCA.
- Set the **Coarse** and **Fine** knobs of both oscillators to desired positions.
- The fundamental frequency of Oscillator B should be set higher than the fundamental frequency of Oscillator A.
- Set the **Depth** knob to a desired position.
- Set the **Wavefold** faders of both oscillators to desired positions.
- Set the **Symmetry Bias Attenuverters** of both oscillators to desired positions.
- Set the level of the VCA to a desired position.

Control Path:

- Enable the 1V/Oct linking by pressing the **Link Button** so that it illuminates white.
- Enable the modulation routing to the **Wavefold CV Input** of Oscillator A by holding down the **Index Button** and then pressing the **Mod Button**.
- Enable the modulation routing to the **Wavefold CV Input** of Oscillator B by holding down the **Index Button** and then pressing the **Sub Button**.
- Enable the modulation routing to the **Symmetry Bias Input** of Oscillator A by holding down the **Index Button** and then pressing the **LFO Button**.
- Enable the modulation routing to the **Symmetry Bias Input** of Oscillator B by holding down the **Index Button** and then pressing the **Link Button**.
- Set the **Index knob** to a desired position.
- Set the **Lin/Exp Toggle** of Oscillator A to a desired response curve.
- Set the **FM Attenuator** of Oscillator A to a desired position.
- Connect the 1V/Oct output of a sequencer or keyboard to the

1V/Oct Input of Oscillator A.

- Connect the gate output of the sequencer or keyboard to the trigger input of an envelope generator.
- Connect the CV output of the envelope generator to a multiple.
- Connect one copy of the envelope generator CV signal to the CV input of the filter and set the corresponding CV attenuator to a desired position.
- Connect a second copy of the envelope generator CV signal to the CV input of the VCA and set the corresponding CV attenuator to a desired position.
- Set the envelope stages to desired positions.

Formant Voice:

Summary: The sine waveform of Oscillator A is half wave rectified and the square waveform of Oscillator B is lowered by one octave and set to hard synchronise Oscillator A. The product of these two signals can be monitored at the **Multiply Output** where it can then be connected to the rest of the **East Coast Synth Voice** audio path. The sequencer or keyboard sends voltages to **Cš-L** while simultaneously triggering the envelope generator. The CV output of the envelope generator opens the filter and VCA, allowing **Cš-L**'s signal to pass through.

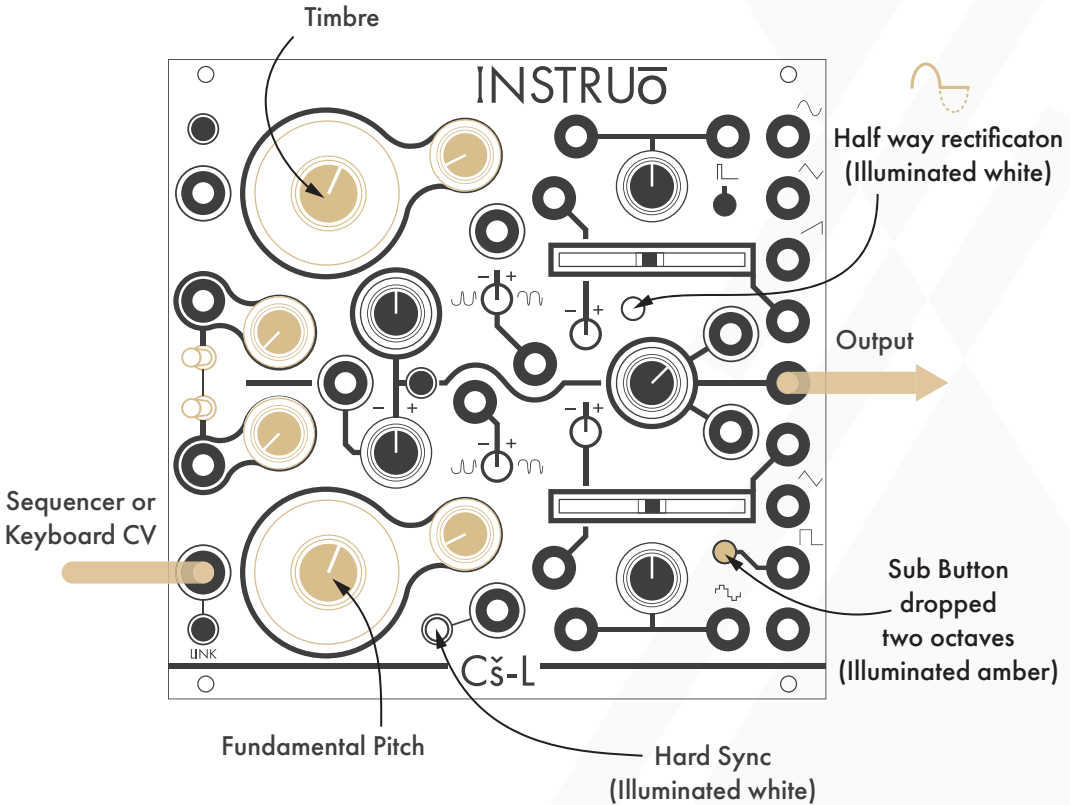

Audio Path:

- Create an **East Coast Synth Voice** audio path using the **Multiply Output**.
- Press the **Ring/AM/Rect Button** so that it is illuminated white and set to **Half Wave Rectification** mode.
- Press the **Sub Button** so that it is illuminated amber and the square waveform's frequency is lowered by two octaves.
- Press the **Sync Button** so that it is illuminated white and the square waveform of Oscillator B is hard synchronising Oscillator A.
- Ensure that both **FM Attenuators** are set fully anticlockwise.
- The frequency of Oscillator B acts as the fundamental frequency.
- Set the **Coarse** and **Fine** knobs of Oscillator B to desired positions.
- The frequency of Oscillator A acts as a timbre control.
- Set the **Coarse** and **Fine** knobs of Oscillator A to desired positions.
- Set the **Depth** knob to a desired position.

Control Path:

- Create an **East Coast Synth Voice** control path.

Spooky Theremin Voice:

The sine waveform of Oscillator B is minutely modulated by the LFO sine waveform of Oscillator A. The sequencer or keyboard sends voltages to CŠ-L.

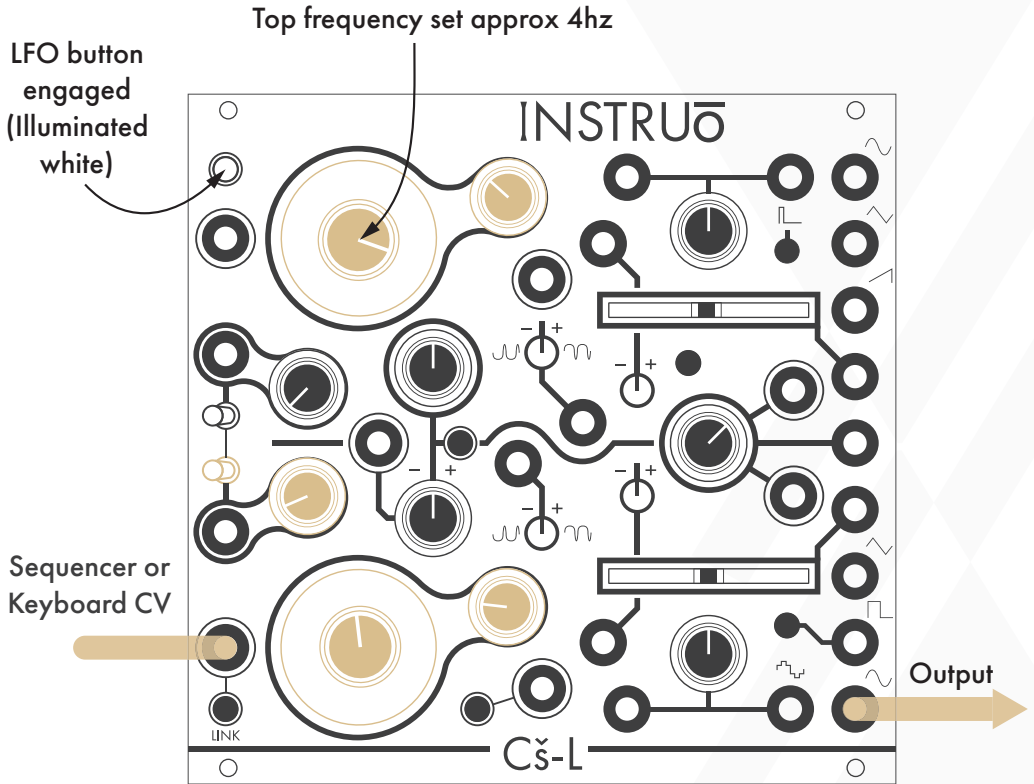

Audio Path:

- **Monitor** from the **Sine Output** Oscillator B.
- Set the **Coarse** and **Fine** knobs of Oscillator B to desired positions.

Control Path:

- Connect the 1V/Oct output of a sequencer or keyboard to the **1V/Oct Input** of Oscillator A.
- Press the **LFO Button** so that it is illuminated white and **LFO Mode** is enabled.
- Set the **Coarse** knob of Oscillator A to 4:00 (around 4Hz) and use the **Fine** knob of Oscillator A for fine tuning the frequency.
- Set the **Lin/Exp Toggle** of Oscillator B to a linear response curve.
- Slightly turn the **FM Attenuator** of Oscillator B to a desired position. A little goes a long way.

Wavefold to multiply with sync and FM:

Summary: Oscillator A is hard synchronised to the **Square** waveform of Oscillator B. The **Final** waveform of Oscillator A is multiplied with the **Sine** waveform of Oscillator B. The **Sine** waveform of Oscillator B also modulates the frequency of Oscillator A. The sequencer or keyboard sends voltages to Oscillator B, effectively changing the fundamental frequency of the sound source. Oscillator A acts as a timbre control.

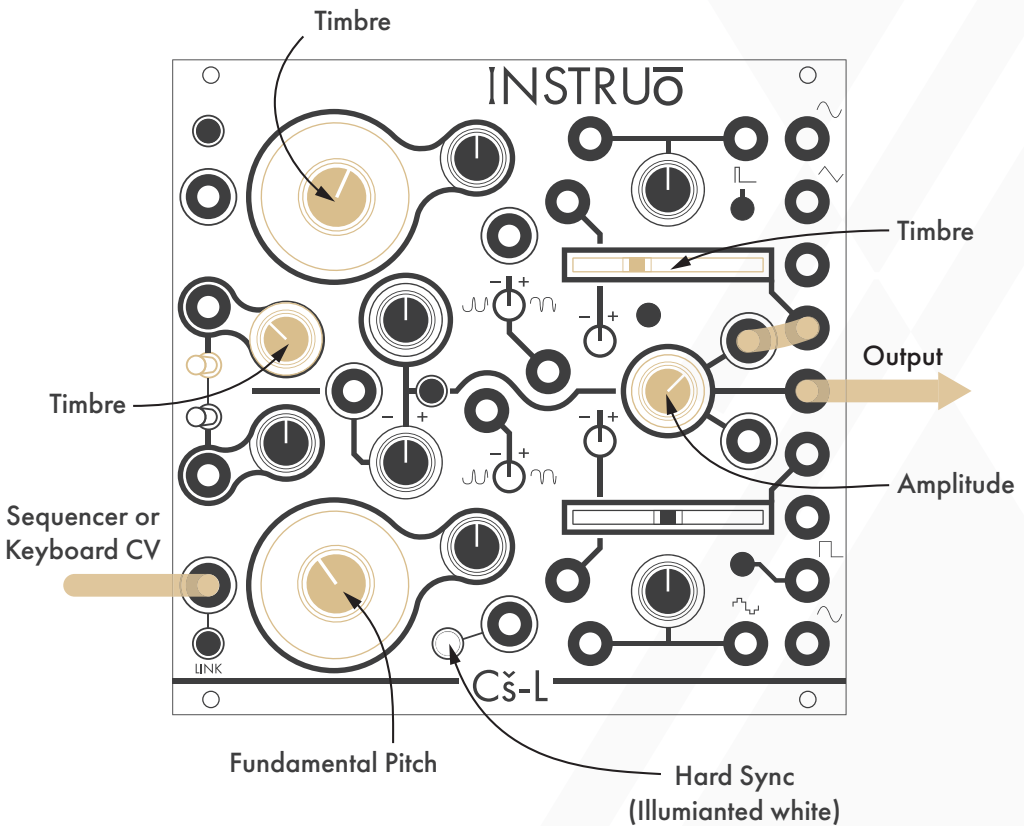

Audio Path:

- Connect the **Final Output** of Oscillator A to the **Multiply Modulator Input**.
- Monitor the **Multiply Output**.
- Press the **Sync Button** so that it is illuminated white and **Hard Synchronisation** is enabled.
- Set the **Coarse** and **Fine** knobs of both oscillators to desired positions.
- Set the **Wavefold** fader of Oscillator A to a desired position.
- Set the **Symmetry Bias Attenuverter** of Oscillator A to a desired position.
- Set the **FM Attenuator** of Oscillator A to a desired position.
- Set the **Lin/Exp Toggle** of Oscillator A to a desired position.
- Set the **Depth** knob to a desired position.

Control Path:

- Connect the 1V/Oct output of a sequencer or keyboard to the **1V/Oct Input** of Oscillator B.

The Bonnie Racket Voice:

The **PWM** output of both oscillators are ring modulated. The ring modulated signal sums with the **Sine** waveform of Oscillator A and then sent through the wavefolder. Both oscillators exponentially frequency modulate each other. The **Final Output** of Oscillator A can then be connected to the rest of the **East Coast Synth Voice** audio path. The sequencer or keyboard sends voltages to **Cš-L** while simultaneously triggering the envelope generator. The CV output of the envelope generator opens the filter and VCA, allowing **Cš-L**'s signal to pass through. More traditional East Coast patches would incorporate separate envelope generators for the filter and VCA.

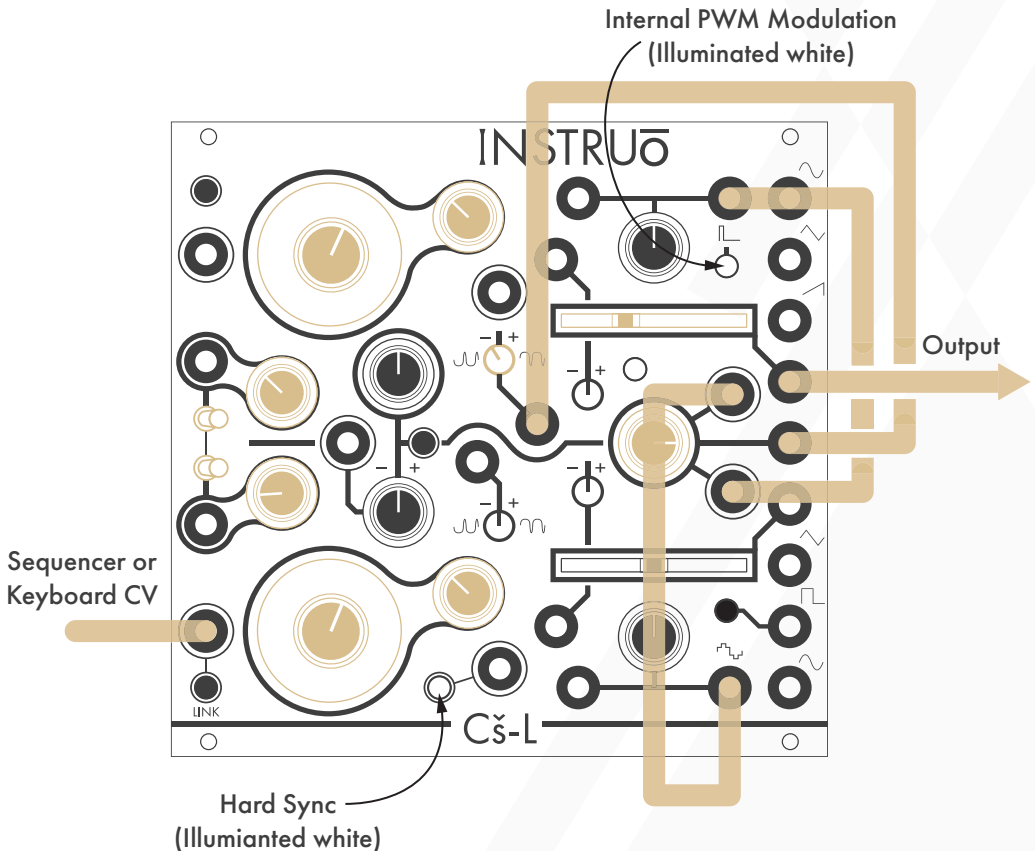

Audio Path:

- Create an **East Coast Synth Voice** audio path using the **Final Output** of Oscillator A.
- Connect the **PWM Output** of Oscillator A to the **Multiply Carrier Input**.
- Connect the **PWM Output** of Oscillator B to the **Multiply Modulator Input**.
- Connect the **Multiply Output** to the **Symmetry Bias Input** of Oscillator A.
- Press the **Sync Button** so that it is illuminated white and Oscillator B is hard synchronising Oscillator A.
- Press the **Mod Button** so that it is illuminated white and **Index** modulation is applied to the **PWM CV Inputs** of both Oscillators.
- Set the **Lin/Exp Toggles** of both oscillators to an exponential response curve.
- Set the **FM Attenuators** of both oscillators to desired positions.
- Set the **PWM** knobs of both oscillators to desired positions.
- Set the **Coarse** and **Fine** knobs of both oscillators to desired positions.
- Set the **Wavefold** fader of Oscillator A to a desired position.
- Set the **Symmetry Bias Attenuverter** of Oscillator A to a desired position.
- Set the **Multiply Output** to a desired position.
- Set the **Index** knob to a desired position.

Control Path:

- Create an **East Coast Synth Voice** control path.

Five Separate Modules At Once:

OSC A AS AN LFO

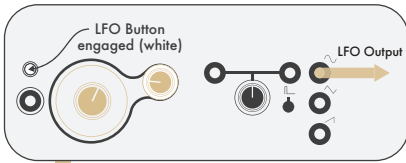

OSC A SYMMETRY INPUT AS WAVEFOLDER

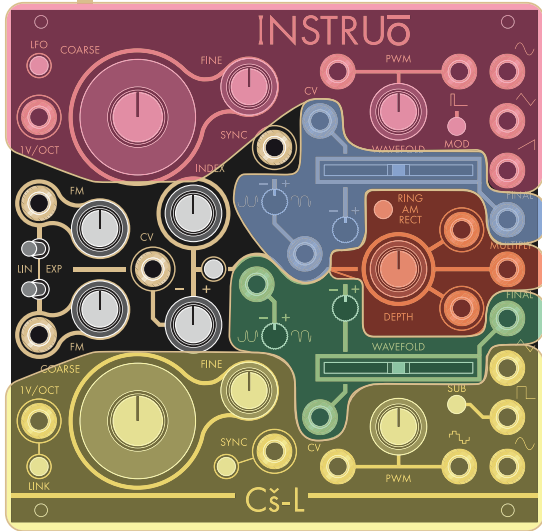
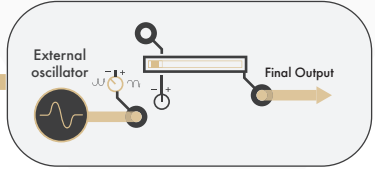

MULTIPLY BUS AS VCA

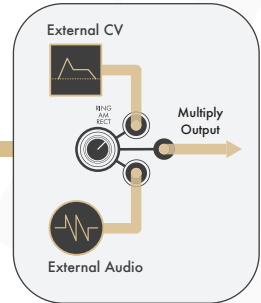

OSC B AS AN OSCILLATOR

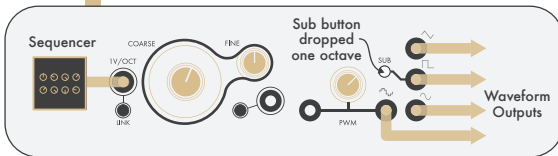

OSC B SYMMETRY INPUT AS WAVEFOLDER

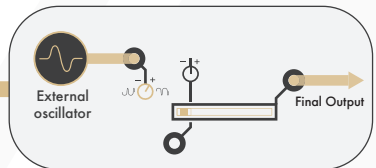

Osc A as LFO:

- Press the **LFO Button** so that the button is illuminated white.
- Set the **Coarse** and **Fine** knobs to a desired position.
- Output from any of the waveform outputs of Oscillator A.

Osc A as Wavefolder:

- Ensure that the **Wavefold** fader is set to its minimum position (fully left).
- Patch an external audio rate signal to the **Symmetry Bias Input**.
- Set the **Symmetry Bias Attenuverter** to a desired position. This parameter controls the amount of wavefolding applied to the signal.
- Monitor the **Final Output** of Oscillator A.

Osc B as Oscillator:

- Set the **Coarse** and **Fine** knobs to a desired position.
- Ensure that the 1V/Oct output of a sequencer or keyboard is connected to the **1V/Oct Input** of Oscillator B.
- Press the **Sub Button** so that the button is illuminated white, and the square waveform's frequency is lowered by one octave.

Multiply as VCA:

- Connect an audio signal to the **Multiply Carrier Input**.
- Connect a control voltage signal to the **Multiply Modulator Input**.
- Ensure that **Ring Modulation Mode** is set and the **Ring/AM/Rect Button** is unilluminated.
- Set the **Depth** knob to a desired position.
- Monitor the **Multiply Output**.

OSC B as Wavefolder:

- Ensure that the **Wavefold** fader is set to its minimum position (fully left).
- Patch an external audio rate signal to the **Symmetry Bias Input**.
- Set the **Symmetry Bias Attenuverter** to a desired position. This parameter controls the amount of wavefolding applied to the signal.
- Monitor the **Final Output** of Oscillator B.

Manual Author: Collin Russell

Manual Design: Dominic D'Sylva

CE This device meets the requirements of the following standards: EN55032, EN55103-2, EN61000-3-2, EN61000-3-3, EN62311.